

*An Online CPD Course
brought to you by
CEDengineering.ca*

Basic Machines – Part 2

Course No: M03-036

Credit: 3 PDH

Elie Tawil, P.E., LEED AP

CED CANADA
engineering.ca
CPD FOR THE PROFESSIONAL

Continuing Education and Development, Inc.

P: (877) 322-5800

info@cedengineering.ca

www.cedengineering.ca

This course was adapted from the Naval Education and Training Professional Development and Technology Center, Publication No, NAVEDTRA 14037 - training course, “Basic Machines”, which is in the public domain.

CHAPTER 7

WORK

CHAPTER LEARNING OBJECTIVES

Upon completion of this chapter, you should be able to do the following:

- Define the term "work" when applied to mechanical power.

MEASUREMENT

You know that machines help you to do work. What is work? Work doesn't mean simply applying a force. If that were so, you would have to consider that the sailor in figure 7-1 is doing work. He is busy applying his 220-pound force on the seabag. However, no work is being done!

Work in the mechanical sense, is done when a resistance is overcome by a force acting through a measurable distance. Now, if that sailor were to lift his 90-pound bag off the deck and put it on his bunk, he would be doing work. He would be overcoming a resistance by applying a force through a distance.

Notice that work involves two factors—force and movement through a distance. You measure force in pounds and distance in feet. Therefore, you measure work in units called foot-pounds. You do 1 foot-pound of work when you lift a 1-pound weight through a height

of 1 foot. You also do 1 foot-pound of work when you apply 1 pound of force on any object through a distance of 1 foot. Writing this as a formula, it becomes—

$$\begin{array}{ccccc} \text{WORK} & = & \text{FORCE} & = & \text{DISTANCE} \\ \text{(foot-pounds)} & & \text{(pounds)} & & \text{(feet)} \end{array}$$

Thus, if you lift a 90-pound bag through a vertical distance of 5 feet, you will do

$$\text{WORK} = 90 \times 5 = 450 \text{ ft-lb.}$$

You should remember two points about work

1. In calculating the work done, you measure the actual resistance being overcome. The resistance is not necessarily the weight of the object you want to move. To understand this more clearly, look at the job the sailor in figure 7-2 is doing. He is pulling a 900-pound load of supplies 200 feet along the dock. Does this mean that he



Figure 7-1.—No work is being done.



Figure 7-2.—Working against friction.

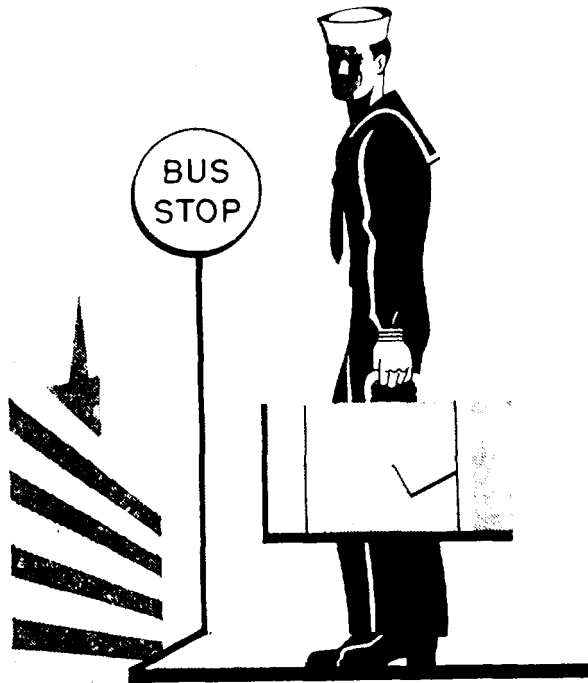

Figure 7-3.—No motion, no work.

is doing 900×200 , or 180,000 foot-pounds of work? Of course not. He isn't working against the pull of gravity—or the total weight—of the load. He's pulling only against the rolling friction of the truck and that may be as little as 90 pounds. That is the resistance that is being overcome. Always be sure you know what resistance is being overcome by the effort, as well as the distance through which it is moved. The resistance in one case may be the weight of the object; in another it may be the frictional resistance of the object as it is dragged or rolled along the deck.

2. You have to move the resistance to do any work on it. Look at the sailor in figure 7-3. The poor guy has been holding that suitcase for 15 minutes waiting for the bus. His arm is getting tired; but according to the definition of work, he isn't doing any because he isn't moving the suitcase. He is merely exerting a force against the pull of gravity on the bag.

You already know about the mechanical advantage of a lever. Now consider how it can be used to get work done easily. Look at figure 7-4. The load weighs 300 pounds, and the sailor wants to lift it up onto a platform a foot above the deck. How much work must he do? Since he must raise 300 pounds 1 foot, he must do 300×1 , or 300 foot-pounds of work.

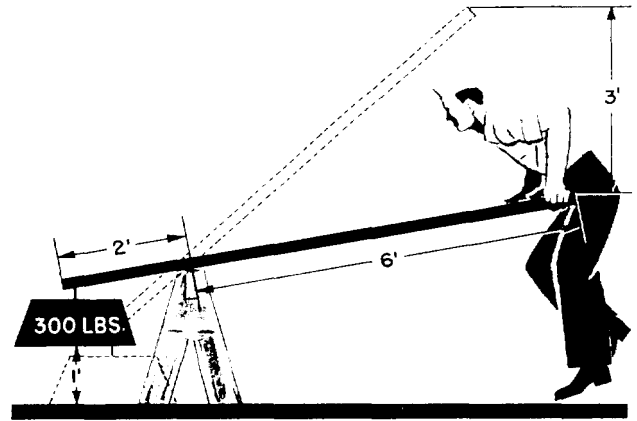

Figure 7-4.—Push'em up.

He can't make this weight any smaller with any machine. If he uses the 8-foot plank as shown, he can do the amount of work by applying a smaller force through a longer distance. Notice that he has a mechanical advantage of 3, so a 100-pound push down on the end of the plank will raise the 300-pound crate. Through how long a distance will he have to exert that 100-pound push? If he neglects friction, the work he exerts on the machine will be equal to the work done by the machine. In other words,

$$\text{work put in} = \text{work put out.}$$

Since $\text{Work} = \text{Force} \times \text{Distance}$, you can substitute $\text{Force} \times \text{Distance}$ on each side of the work equation. Thus:

$$F_1 \times S_1 = F_2 \times S_2$$

in which

$$F_1 = \text{effort applied, in pounds}$$

$$S_1 = \text{distance through which effort moves, in feet}$$

$$F_2 = \text{resistance overcome, in pounds}$$

$$S_2 = \text{distance resistance is moved, in feet}$$

Now substitute the known values, and you get:

$$100 \times S_1 = 300 \times 1$$

$$S_1 = 3 \text{ feet}$$

The advantage of using the lever is not that it makes any less work for you, but it allows you to do the job with the force at your command. You'd probably have some difficulty lifting 300 pounds directly upward without a machine to help you!

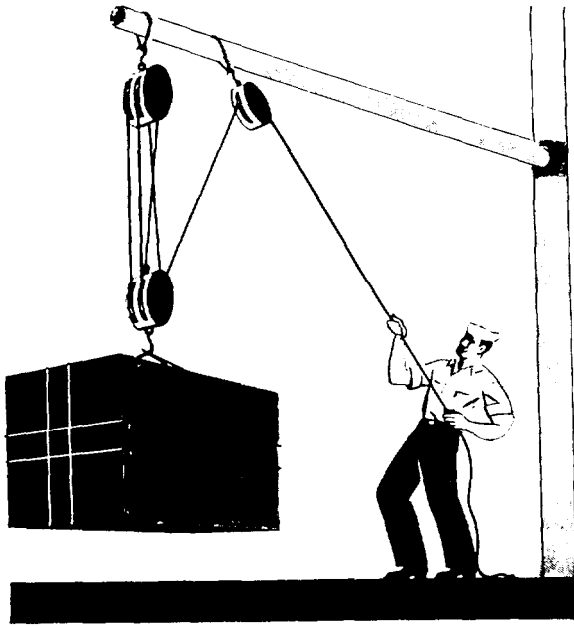

Figure 7-5.—A block and tackle makes work easier.

A block and tackle also makes work easier. Like any other machine, it can't decrease the total amount of work to be done. With a rig like the one shown in figure 7-5, the sailor has a mechanical advantage of 5, neglecting friction. Notice that five parts of the rope go to and from the movable block. To raise the 600-pound load 20 feet, he needs to exert a pull of only one-fifth of 600—or 120 pounds. He is going to have to pull more than 20 feet of rope through his hands to do this. Use the formula again to figure why this is so:

Work input = work output

$$F_1 \times S_1 = F_2 \times S_2$$

And by substituting the known values:

$$120 \times S_1 = 600 \times 20$$

$$S_1 = 100 \text{ feet.}$$

This means that he has to pull 100 feet of rope through his hands to raise the load 20 feet. Again, the advantage lies in the fact that a small force operating through a large distance can move a big load through a small distance.

The sailor busy with the big piece of machinery in figure 7-6 has his work cut out for him. He is trying to seat the machine squarely on its foundations. He must shove the rear end over one-half foot against a frictional

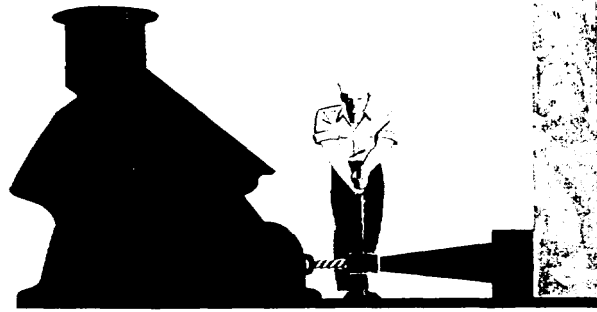

Figure 7-6.—A big push.

resistance of 1,500 pounds. The amount of work to be done is $1,500 \times 1/2$, or 750 foot-pounds. He will have to apply at least this much force on the jack he is using. If the jack has a $2 \frac{1}{2}$ -foot handle— $R = 2 \frac{1}{2}$ feet—and the pitch of the jack screw is one-fourth inch, he can do the job with little effort. Neglecting friction, you can figure it out this way:

Work input = work output

$$F_1 \times S_1 = F_2 \times S_2$$

In which

F_1 = force in pounds applied on the handle;

S_1 = distance in feet that the end of the handle travels in one revolution;

F_2 = resistance to overcome;

S_2 = distance in feet that the head of the jack advanced by one revolution of the screw, or, the pitch of the screw.

And, by substitution,

$$F_1 \times 2 \times 3.14 \times 2 \frac{1}{2} = 1,500 \times 1/48$$

since

$$1/4 \text{ inch} = 1/48 \text{ of a foot}$$

$$F_1 \times 2 \times 2 \frac{1}{2} = 1,500 \times 1/48$$

$$F_1 = 2 \text{ pounds}$$

The jack makes it theoretically possible for the sailor to exert a 1,500-pound push with a 2-pound effort. Look at the distance through which he must apply that effort. One complete turn of the handle represents a distance of 15.7 feet. That 15.7-foot rotation advances the piece of machinery only one-fourth of an inch, or

one-forty-eighth of a foot. You gain force at the expense of distance.

FRICITION

Suppose you are going to push a 400-pound crate up a 12-foot plank; the upper end is 3 feet higher than the lower end. You decide that a 100-pound push will do the job. The height you will raise the crate is one-fourth of the distance through which you will exert your push. The theoretical mechanical advantage is 4. Then you push on the crate, applying 100 pounds of force; but nothing happens! You've forgotten about the friction between the surface of the crate and the surface of the plank. This friction acts as a resistance to the movement of the crate; you must overcome this resistance to move the crate. In fact, you might have to push as much as 150 pounds to move it. You would use 50 pounds to overcome the frictional resistance, and the remaining 100 pounds would be the useful push that would move the crate up the plank.

Friction is the resistance that one surface offers to its movement over another surface. The amount of friction depends upon the nature of the two surfaces and the forces that hold them together.

In many instances friction is useful to you. Friction helps you hold back the crate from sliding down the inclined ramp. The cinders you throw under the wheels of your car when it's slipping on an icy pavement increase the friction. You wear rubber-soled shoes in the gym to keep from slipping. Locomotives carry a supply of sand to drop on the tracks in front of the driving wheels to increase the friction between the wheels and the track. Nails hold structures together because of the friction between the nails and the lumber.

You make friction work for you when you slow up an object in motion, when you want traction, and when you prevent motion from taking place. When you want a machine to run smoothly and at high efficiency, you eliminate as much friction as possible by oiling and greasing bearings and honing and smoothing rubbing surfaces.

Where you apply force to cause motion, friction makes the actual mechanical advantage fall short of the theoretical mechanical advantage. Because of friction, you have to make a greater effort to overcome the resistance that you want to move. If you place a marble and a lump of sugar on a table and give each an equal push, the marble will move farther. That is because rolling friction is always less than sliding friction. You take advantage of this fact whenever you use ball bearings or roller bearings. See figure 7-7.

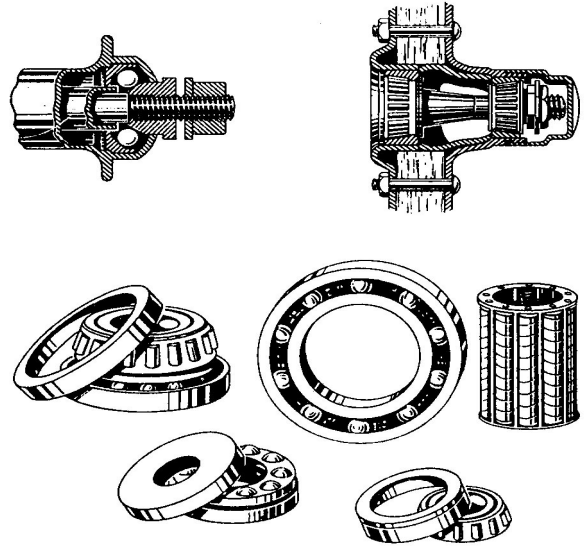

Figure 7-7.—These reduce friction.

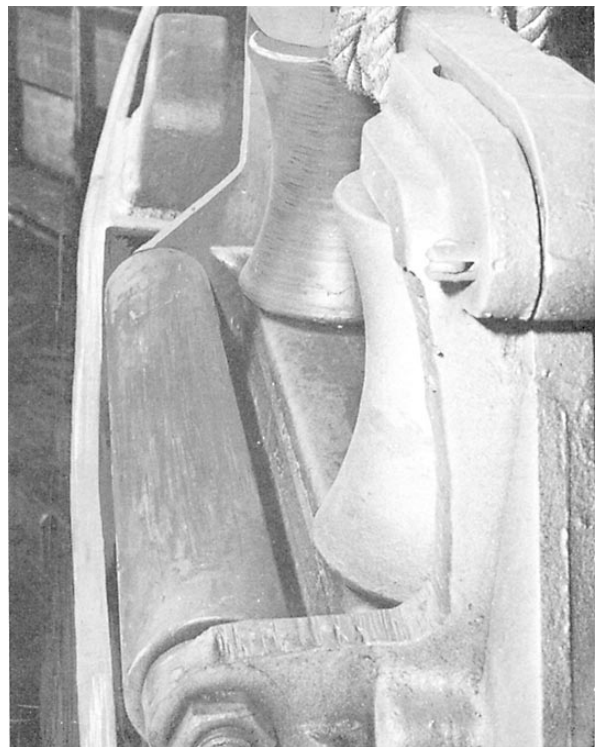

Figure 7-8.—It saves wear and tear.

The Navy takes advantage of that fact that rolling friction is always less than sliding friction. Look at figure 7-8. This roller chock cuts down the wear and tear on lines and cables that are run through it. It also reduces friction and reduces the load the winch has to work against.



Figure 7-9.—Roller bitt saves line.

The roller bitt in figure 7-9 is another example of how you can cut down the wear and tear on lines or cable and reduce your frictional loss.

When you need one surface to move over another, you can decrease the friction with lubricants such as oil, grease, or soap. You can use a lubricant on flat surfaces and gun slides as well as on ball and roller bearings. A lubricant reduces frictional resistance and cuts down wear.

In many situations friction is helpful. However, many sailors have found out about this the hard way—on a wet, slippery deck. You'll find rough grain coverings are used on some of our ships. Here you have friction working for you. It helps you to keep your footing.

EFFICIENCY

To make it easier to explain machine operations, we have neglected the effect of friction on machines up to this point. Friction happens every time two surfaces move against one another. The work used in overcoming the frictional resistance does not appear in the work output. Therefore, it's obvious that you have to put more work into a machine than you get out of it. Thus, no machine is 100 percent efficient.

Take the jack in figure 7-6, for example. The chances are good that a 2-pound force exerted on the handle wouldn't do the job at all. You would need a pull of at least 10 pounds. This shows that only 2 pounds out of the 10 pounds, or 20 percent of the effort, is employed to do the job. The remaining 8 pounds of effort was in overcoming the friction in the jack. Thus, the jack has an efficiency of only 20 percent. Most jacks are inefficient. However, even with this inefficiency, it is possible to deliver a huge push with a small amount of effort.

A simple way to calculate the efficiency of a machine is to divide the output by the input and convert it to a percentage:

$$\text{Efficiency} = \frac{\text{Output}}{\text{Input}}$$

Now go back to the block-and-tackle problem illustrated in figure 7-5. It's likely that instead of being able to lift the load with a 120-pound pull, the sailor would have to use a 160-pound pull through the 100 feet. You can calculate the efficiency of the rig by the following method:

$$\text{Efficiency} = \frac{\text{Output}}{\text{Input}} = \frac{F_2 \times S_2}{F_1 \times S_1}$$

and, by substitution,

$$\text{Efficiency} = \frac{600 \times 20}{160 \times 100} = 0.75 \text{ Or } 75 \text{ percent.}$$

Theoretically, with the mechanical advantage of 12 developed by the cable winch in figure 6-11, you can lift a 600-pound load with a 50-pound push on the handle. If the machine has an efficiency of 60 percent, how big a push would you actually have to apply? Actually, $50 \div 0.60 = 83.3$ pounds. You can check this yourself in the following manner:

$$\text{Efficiency} = \frac{\text{Output}}{\text{Input}}$$

$$= \frac{F_2 \times S_2}{F_1 \times S_1}$$

One revolution of the drum would raise the 600-pound load a distance S_2 of $2\pi r$, or 7.85 feet. To make the drum revolve once, the pinion gear must rotate six times by the handle, and the handle must turn through

a distance S_1 of $6 \times 2\pi R$, or 94.2 feet. Then, by substitution:

$$0.60 = \frac{600 \times 7.85}{F_1 \times 94.2}$$

$$F_1 = \frac{600 \times 7.85}{94.2 \times 0.60} = 83.3 \text{ pounds.}$$

Because this machine is only 60-percent efficient, you have to put 94.2×83.3 , or 7,847 foot-pounds, of work into it to get 4,710 foot-pounds of work out of it. The difference ($7,847 - 4,710 = 3,137$ foot-pounds) is used to overcome friction within the machine.

SUMMARY

Here are some of the important points you should remember about friction, work and efficiency:

You do work when you apply a force against a resistance and move the resistance.

Since force is measured in pounds and distance is measured in feet, we measure work in foot-pounds. One foot-pound of work is the result of a 1-pound force, acting against a resistance through a distance of 1 foot.

Machines help you to do work by making it possible to move a large resistance through a small distance by the application of a small force through a large distance.

Since friction is present in all machines, more work must be done on the machine than the machine actually does on the load.

You can find the efficiency of any machine by dividing the output by the input.

Friction is the resistance that one surface offers to movement over a second surface.

Friction between two surfaces depends upon the nature of the materials and the size of the forces pushing them together.

CHAPTER 8

POWER

CHAPTER LEARNING OBJECTIVES

Upon completion of this chapter, you should be able to do the following:

- *Define the term "power".*
- *Determine horsepower ratings.*

It's all very well to talk about how much work a person can do. The payoff is how long it takes him or her to do it. Look at the sailor in figure 8-1. He has lugged 3 tons of bricks up to the second deck of the new barracks. However, it has taken him three 10-hour days—1,800 minutes—to do the job. In raising the 6,000 pounds 15 feet, he did 90,000 foot-pounds (ft-lb) of work. Remember, force x distance = work. Since it took him 1,800 minutes, he has been working at $90,000 \div 1,800$, or 50 foot-pounds of work per minute.

That's power—the rate of doing work. Thus, power always includes a time element. Doubtless you could do the same amount of work in one 10-hour day, or 600 minutes. This would mean that you would work at the rate of $90,000 \div 600 = 150$ foot-pounds per minute. You then would have a power value three times as much as that of the sailor in figure 8-1.

Apply the following formula:

$$\text{Power} = \frac{\text{Work, in ft-lb}}{\text{Time, in minutes}}$$



Figure 8-1.-Get a horse.

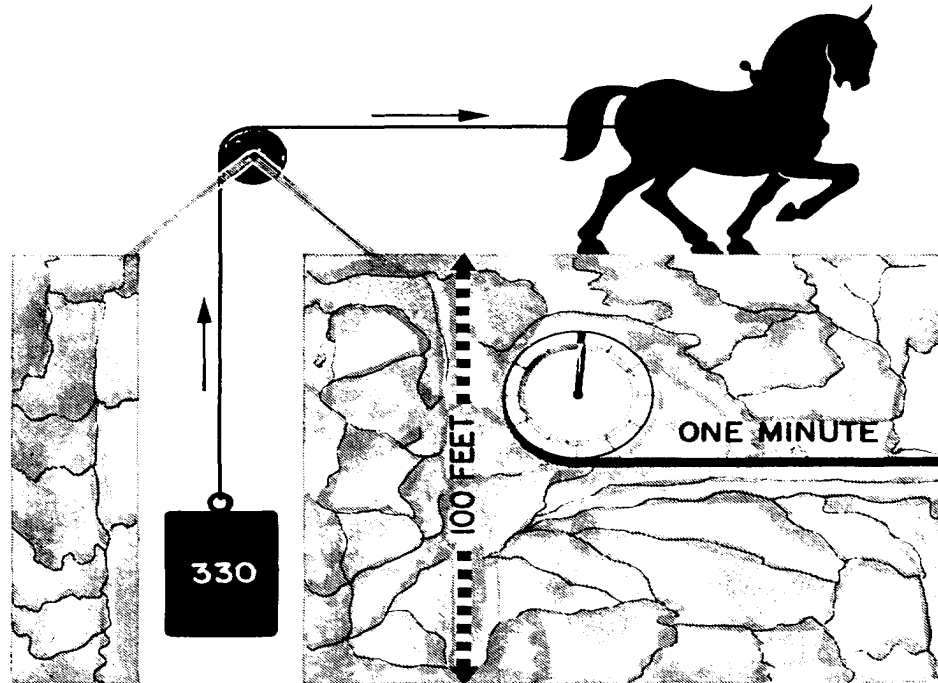

Figure 8-2.-One horsepower.

HORSEPOWER

You measure force in pounds, distance in feet, and work in foot-pounds. What is the common unit used for measuring power? It is called horsepower (hp). If you want to tell someone how powerful an engine is, you could say that it is many times more powerful than a man or an ox or a horse. But what man? and whose ox or horse? James Watt, the man who invented the steam engine, compared his early models with the horse. By experiment, he found that an average horse, hitched to a rig as shown in figure 8-2, could lift a 330-pound load straight up a distance of 100 feet in 1 minute. Scientists agree that 1 horsepower equals 33,000 foot-pounds of work done in 1 minute.

Since 60 seconds equals a minute, 1 horsepower is equal to $\frac{33,000}{60} = 550$ foot-pounds per second. Use the following formula to figure horsepower:

$$\text{Horsepower} = \frac{\text{Power (in ft-lb per min)}}{33,000}$$

CALCULATING POWER

It isn't difficult to figure how much power you need to do a certain job in a given length of time. Nor is it

difficult to predict what size engine or motor you need to do it. Suppose an anchor winch must raise a 6,600-pound anchor through 120 feet in 2 minutes. What must be the theoretical horsepower rating of the motor on the winch?

The first step is to find the rate at which the work must be done using the formula:

$$\text{Power} = \frac{\text{work}}{\text{time}} = \frac{\text{force} \times \text{distance}}{\text{time}}$$

Substitute the known values in the formula, and you get:

$$\text{Power} = \frac{6,600 \times 120}{2} = 396,000 \text{ ft-lb/min}$$

So far, you know that the winch must work at a rate of 396,000 ft-lb/min. To change this rate to horsepower, you divide by the rate at which the average horse can work—33,000 ft-lb/min.

$$\begin{aligned} \text{Horsepower} &= \frac{\text{Power (in ft-lb per min)}}{33,000} \\ &= \frac{396,000}{33,000} = 12 \text{ hp} \end{aligned}$$

Theoretically, the winch would have to work at a rate of 12 horsepower to raise the anchor in 2 minutes. Of course, you've left out all friction in this problem, so the winch motor would actually have to be larger than 12 hp.

You raise planes from the hangar deck to the flight deck of a carrier on an elevator. Some place along the line, an engineer had to figure out how powerful the motor had to be to raise the elevator. It's not too tough when you know how. Allow a weight of 10 tons for the elevator and 5 tons for the plane. Suppose that you want to raise the elevator and plane 25 feet in 10 seconds and that the overall efficiency of the elevator mechanism is 70 percent. With that information you can figure what the delivery horsepower of the motor must be. Set up the formulas:

$$\text{Power} = \frac{\text{force} \times \text{distance}}{\text{time}}$$

$$\text{hp} = \frac{\text{power}}{33,000}$$

Substitute the known values in their proper places, and you have:

$$\text{Power} = \frac{30,000 \times 25 \text{ ft}}{10/60 \text{ minute}} = 4,500,000 \text{ ft-lb/min.}$$

$$\text{hp} = \frac{4,500,000}{33,000} = 136.4 \text{ hp}$$

So, you need 136.4 horsepower if the engine has 100 percent overall efficiency. You want to use 70 percent efficiency, so you use the formula:

$$\text{Efficiency} = \frac{\text{Output}}{\text{Input}}$$

$$\text{Input} = \frac{136.4}{0.70} = 194.8 \text{ hp}$$

This is the rate at which the engine must be able to work. To be on the safe side, you'd probably select a 200-horsepower auxiliary to do the job.

FIGURING THE HORSEPOWER RATING OF A MOTOR

You have probably seen the horsepower rating plates on electric motors. You may use several methods to determine this rating. One way to find the rating of a

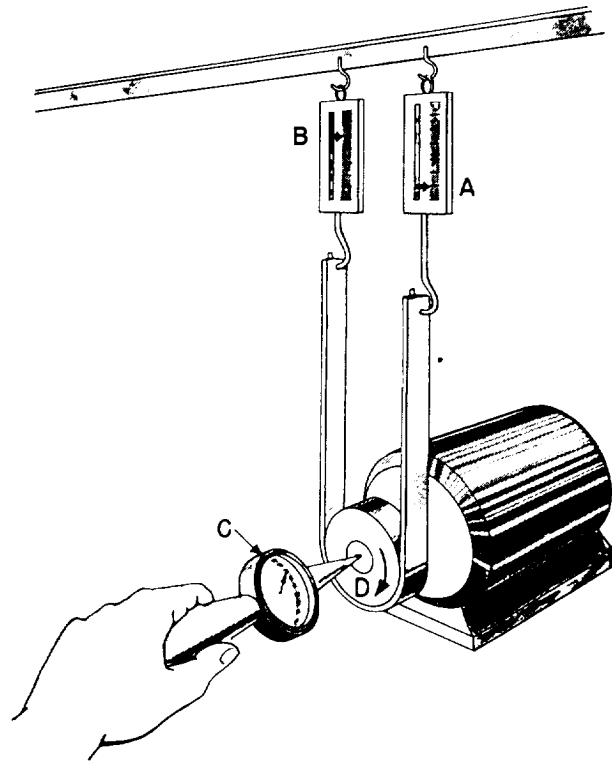

Figure 8-3.-A prony brake.

motor or a steam or gas engine is with the use of the prony brake. Figure 8-3 shows you the prony brake setup. A pulley wheel is attached to the shaft of the motor and a leather belt is held firmly against the pulley. Attached to the two ends of the belts are spring scales. When the motor is standing still, each scale reads the same— 15 points. When the pulley turns in a clockwise direction, the friction between the belt and the pulley makes the belt try to move with the pulley. Therefore, the pull on scale A will be greater than 15 pounds, and the pull on scale B will be less than 15 pounds.

Suppose that scale A reads 25 pounds and scale B reads 5 pounds. That tells you the drag, or the force against which the motor is working, is $25 - 5 = 20$ pounds. In this case the normal speed of the motor is 1,800 revolutions per minute (rpm) and the diameter of the pulley is 1 foot.

You can find the number of revolutions by holding the revolution counter (fig. 8-3, C) against the end of the shaft for 1 minute. This counter will record the number of turns the shaft makes per minute. The distance (D) that any point on the pulley travels in 1 minute is

equal to the circumference of the pulley times the number of revolutions or $3.14 \times 1 \times 1,800 = 5,652$ ft.

You know that the motor is exerting a force of 20 pounds through that distance. The work done in 1 minute is equal to the force times the distance, or $\text{work} = F \times D = 20 \times 5,652 = 113,040$ ft-lb/min. Change this to horsepower:

$$\frac{113,040}{33,000} = 3.43 \text{ hp}$$

Two common motor or engine ratings with which you are familiar are the 1/16-hp motor of an

electric mixer and the 1/4-hp motor of a washing machine.

SUMMARY

Remember two important points about power:

Power is the rate at which work is done.

Horsepower is the unit of measurement by which power is equivalent to 33,000 foot-pounds of work per minute, or 550 foot-pounds per second.

CHAPTER 9

FORCE AND PRESSURE

CHAPTER LEARNING OBJECTIVES

Upon completion of this chapter, you should be able to do the following:

- *Explain the difference in force and pressure.*
- *Discuss the operation of force- and pressure-measuring devices.*

By this time you should have a pretty good idea of what force is. Now you will learn the difference between force and pressure and how force affects pressure.

FORCE

Force is the pull of gravity exerted on an object or an object's thrust of energy against friction. You apply a force on a machine; the machine, in turn, transmits a force to the load. However, other elements besides men and machines can also exert a force. For example, if you've been out in a sailboat, you know that the wind can exert a force. Further, after the waves have knocked you on your ear a couple of times, you have grasped the idea that water, too, can exert a force. Aboard ship, from reveille to taps you are almost constantly either exerting forces or resisting them.

MEASURING FORCE

Weight is a measurement of the force, or pull of gravity, on an object. You've had a lot of experience in

measuring forces. At times, you have estimated or "guessed" the weight of a package you were going to mail by "hefting" it. However, to find its accurate weight, you would have put it on a force-measuring device known as a scale. Scales are of two types: spring and balanced.

Spring Scale

You can readily measure force with a spring scale. An Englishman named Hooke invented the spring scale. He discovered that hanging a 1-pound weight on a spring caused the spring to stretch a certain distance and that hanging a 2-pound weight on the spring caused it to stretch twice as far. By attaching a pointer to the spring and inserting the pointer through a face, he could mark points on the face to indicate various measurements in pounds and ounces.

We use this type of scale to measure the pull of gravity—the weight-of an object or the force of a pull exerted against friction, as shown in figure 9-1.

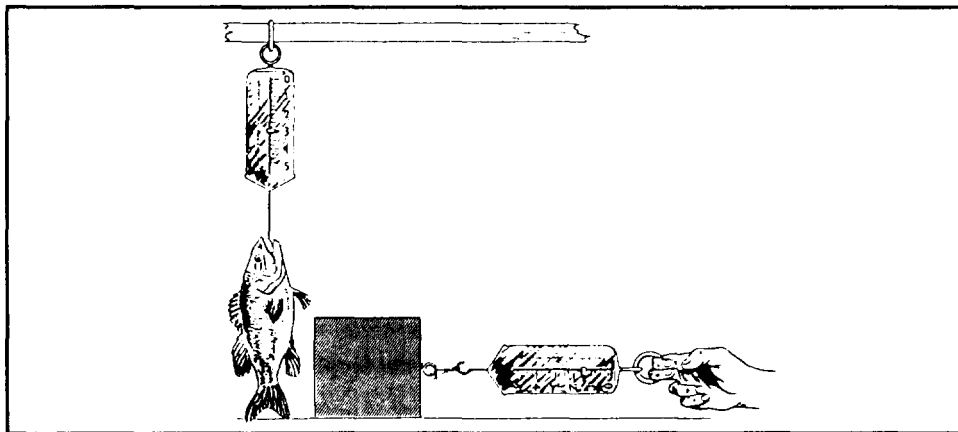

Figure 9-1.—You can measure force with a scale.

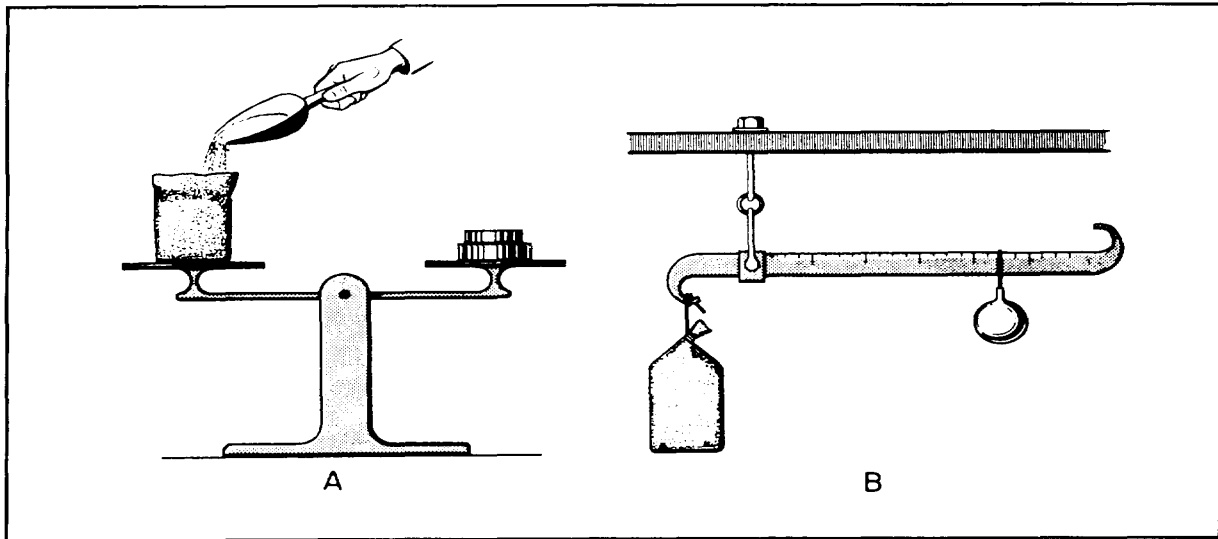

Figure 9-2.—Balances.

Unfortunately, the more springs are used, the more they lose their ability to snap back to their original position. Hence, an old spring or an overloaded spring will give inaccurate readings.

Balanced Scale

The problem with the spring-type scale eventually led to the invention of the balanced scale, shown in figure 9-2. This type of scale is an application of first-class levers. The one shown in figure 9-2, A, is the simplest type. Since the distance from the fulcrum to the center of each platform is equal, the scales balance when equal weights are placed on the platforms. With your knowledge of levers, you can figure out how the steel yard shown in figure 9-2, B, operates.

PRESSURE

Pressure is the amount of force within a specific area. You measure air, steam, and gas pressure and the fluid pressure in hydraulic systems in pounds per square inch (psi). However, you measure water pressure in pounds per square foot. You'll find more about pressure measurements in chapter 10. To help you better understand pressure, let's look at how pressure affects your ability to walk across snow.

Have you ever tried to walk on freshly fallen snow to have your feet break through the crust when you put your weight on it? If you had worn snowshoes, you could have walked across the snow without sinking; but do you know why? Snowshoes do not reduce your weight, or the amount of force, exerted on the snow; they merely distribute it over a larger area. In doing that, the snowshoes reduce the pressure per square inch of the force you exert.

Let's figure out how that works. If a man weighs 160 pounds, that weight, or force, is more or less evenly distributed by the soles of his shoes. The area of the soles of an average man's shoes is roughly 60 square inches. Each of those square inches has to carry $160 \div 60 = 2.6$ pounds of that man's weight. Since 2 to 6 pounds per square inch is too much weight for the snow crust to support, his feet break through.

When the man puts on snowshoes, he distributes his weight over an area of about 900 square inches, depending on the size of the snowshoes. The force on each of those square inches is equal to only $160 \div 900 = 0.18$ pounds. Therefore, with snowshoes on, he exerts a pressure of 0.18 psi. With this decreased pressure, the snow can easily support him.

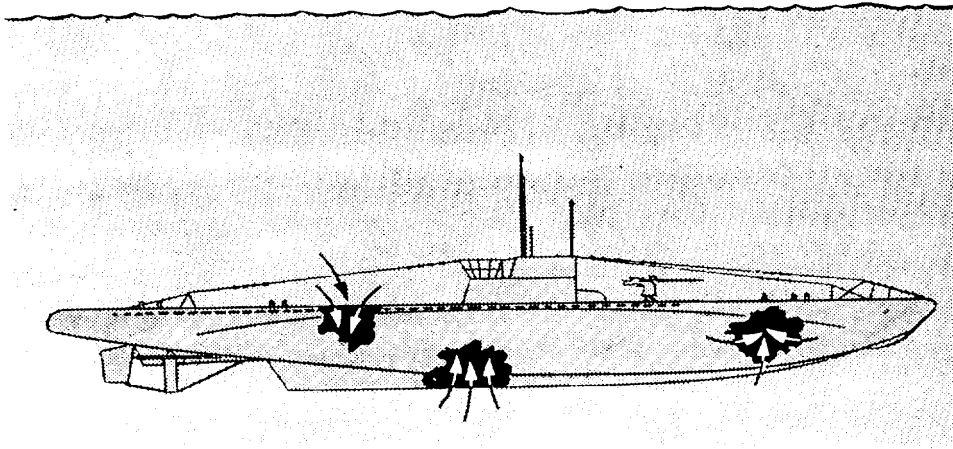

Figure 9-3.-Fluids exert pressure in all directions.

CALCULATING PRESSURE

To calculate pressure, divide the force by the area on which you apply force. Use the following formula:

$$\text{Pressure, in psi} = \frac{\text{Force, in lb}}{\text{Area, in sq in.}}$$

or

$$P = \frac{F}{A}$$

To understand this idea, follow this problem. A fresh water holding tank aboard a ship is 10 feet long, 6 feet wide, and 4 feet deep. Therefore, it holds $10 \times 6 \times 4$, or 240, cubic feet of water. Each cubic foot of water weighs about 62.5 pounds. The total force outside the tank's bottom is equal to the weight of the water: 240×62.5 , or 15,000 pounds. What is the pressure on the bottom of the tank? Since the weight is even on the bottom, you apply the formula $P = \frac{F}{A}$ and substitute the proper values for F and A . In this case, $F = 15,000$ pounds; the area of the bottom in square inches is $10 \times 6 \times 144$, since 144 square inches = 1 square foot.

$$P = \frac{15,000}{10 \times 6 \times 144}$$

Now work out the idea in reverse. You live at the bottom of the great sea of air that surrounds the earth. Because the air has weight—gravity pulls on the air

too—the air exerts a force on every object that it surrounds. Near sea level that force on an area of 1 square inch is roughly 15 pounds. Thus, the air-pressure at sea level is about 15 psi. The pressure gets less and less as you go up to higher altitudes.

With your finger, mark out an area of 1 square foot on your chest. What is the total force pushing on your chest? Again use the formula $P = \frac{F}{A}$. Now substitute 15 psi for P and 144 square inches for A . Then, $F = 144 \times 15$, or 2,160 pounds. The force on your chest is 2,160 pounds per square foot—more than a ton pushing against an area of 1 square foot. If no air were inside your chest to push outward with the same pressure, you'd be flatter than a bride's biscuit.

MEASURING FLUID PRESSURE

All fluids—both liquids and gases—exert pressure. A fluid at rest exerts equal pressure in all directions. As shown in figure 9-3, water will push through a hole in a submarine, whether it is in the top, the bottom, or in one of the sides.

Many jobs aboard ship will require you to know the pressure exerted by a gas or a liquid. For example, knowing the steam pressure inside a boiler is always important. You can use three different gauges to find the pressure of fluids: Bourdon gauge, Schrader gauge, and diaphragm gauge.

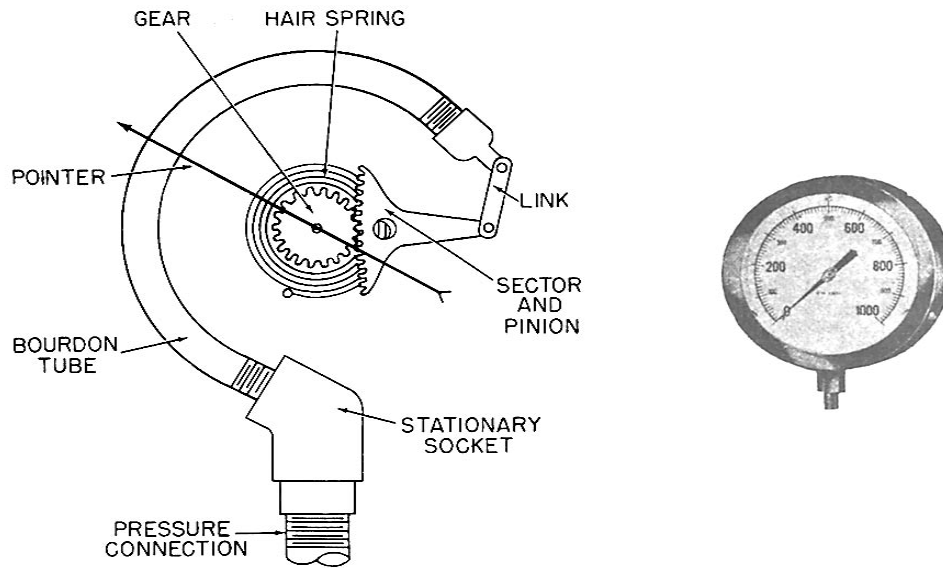

Figure 9-4.-The Bourdon gauge.

Bourdon Gauge

The Bourdon gauge is shown in figure 9-4. It works on the same principle as that of the snakelike, paper party whistle you get at a New Year party, which straightens when you blow into it.

Within the Bourdon gauge is a thin-walled metal tube, somewhat flattened and bent into the form of a C. Attached to its free end is a lever system that magnifies any motion of the free end of the tube. On the fixed end of the gauge is a fitting you thread into a boiler system. As pressure increases within the boiler, it travels through the tube. Like the snakelike paper whistle, the metal tube begins to straighten as the pressure increases inside of it. As the tube straightens, the pointer moves around a dial that indicates the pressure in psi.

The Bourdon gauge is a highly accurate but rather delicate instrument. You can easily damage it. In addition, it malfunctions if pressure varies rapidly. This problem was overcome by the development of another type of gauge, the Schrader. The Schrader gauge (fig. 9-5) is not as accurate as the Bourdon, but it is sturdy and suitable for ordinary hydraulic pressure measurements. It is especially suitable for fluctuating loads.

In the Schrader gauge, liquid pressure actuates a piston. The pressure moves up a cylinder against the resistance of a spring, carrying a bar or indicator with it over a calibrated scale. The operation of this

gauge eliminates the need for cams, gears, levers, and bearings.

Diaphragm Gauge

The diaphragm gauge gives sensitive and reliable indications of small pressure differences. We use the diaphragm gauge to measure the air pressure in the space between inner and outer boiler casings.

In this type of gauge, a diaphragm connects to a pointer through a metal spring and a simple linkage system (fig. 9-6). One side of the diaphragm is exposed to the pressure being measured, while the other side is exposed to the pressure of the atmosphere. Any increase in the pressure line moves the diaphragm upward against the spring, moving the pointer to a higher reading. When the pressure decreases, the spring moves the diaphragm downward, rotating the pointer to a lower reading. Thus, the position of the pointer is balanced between the pressure pushing the diaphragm upward and the spring action pushing down. When the gauge reads 0, the pressure in the line is equal to the outside air pressure.

MEASURING AIR PRESSURE

To the average person, the chief importance of weather is reference to it as an introduction to general conversation. At sea and in the air, advance knowledge of what the weather will do is a matter of great concern

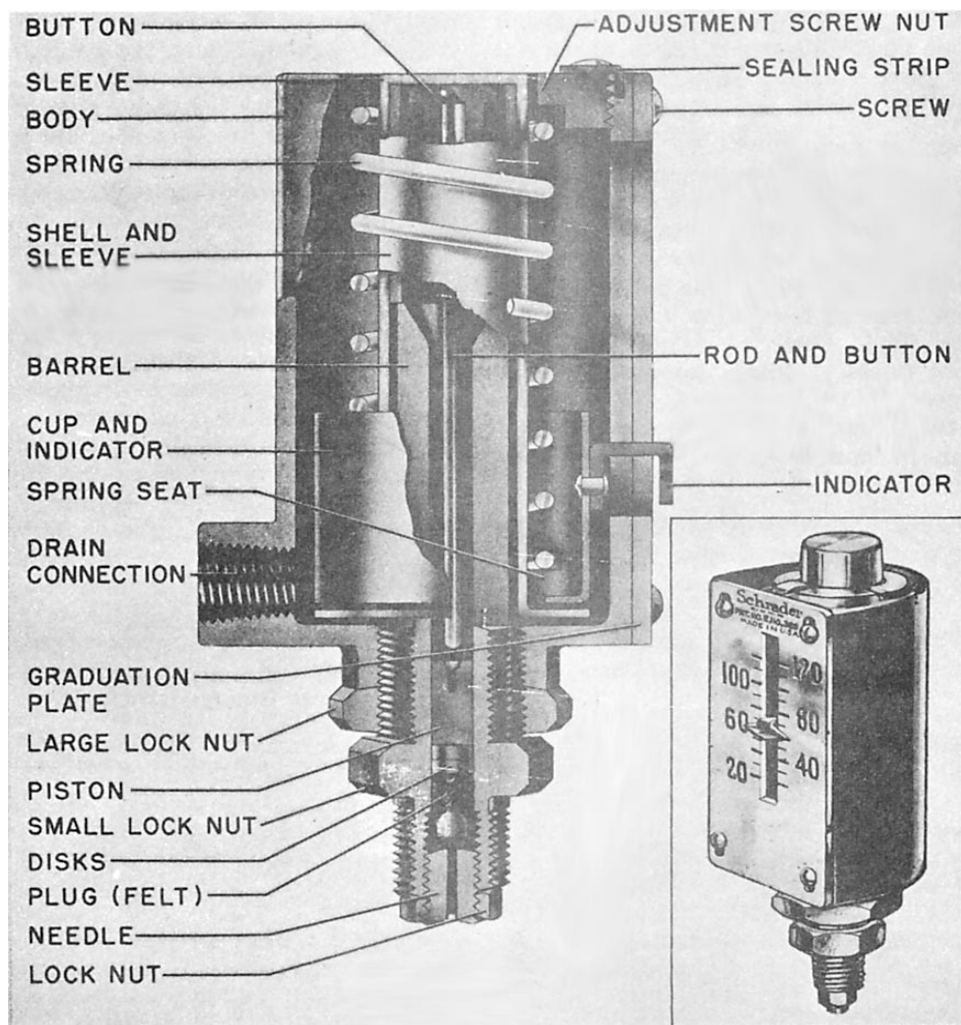

Figure 9-5.—The Schrader gauge.

to all hands. We plan or cancel operations on the basis of weather predictions. Accurate weather forecasts are made only after a great deal of information has been collected by many observers located over a wide area.

One of the instruments used in gathering weather data is the barometer, which measures air pressure. Remember, the air is pressing on you all the time. Normal atmospheric pressure is 14.7 psi. As the weather changes, the air pressure may be greater or less than normal. Air from high-pressure areas always moves toward low-pressure areas, and moving air—or wind—is one of the main causes of weather changes. In general, as air moves into a low-pressure area, it causes wind, rain, and storms. A high-pressure area usually enjoys clear weather. Ships use two types of barometers to measure air pressure: aneroid and mercurial.

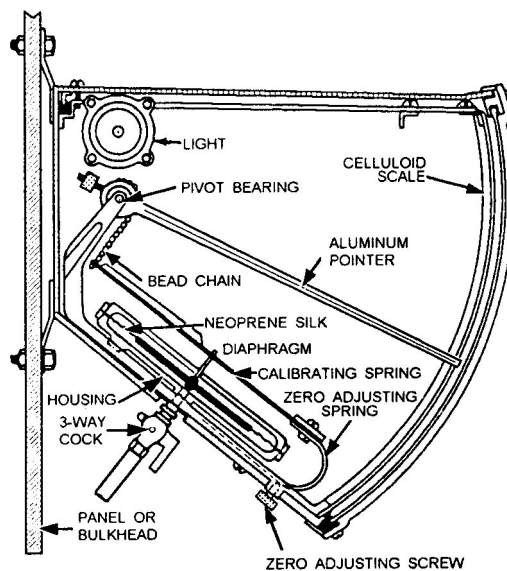

Figure 9-6.—Diaphragm pressure gauge.

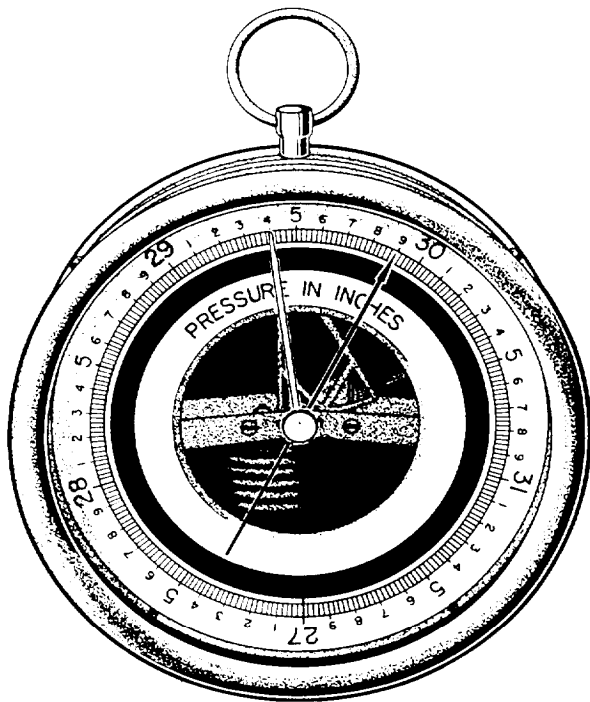

Figure 9-7.-An aneroid barometer.

Since air pressure affects weather, you can see why the use of a barometer is so important to ships. However, not so apparent is the importance of air pressure in the operation of the ship's engine. For that purpose air pressure is measured with a gauge called a manometer.

Aneroid Barometer

The aneroid barometer shown in figure 9-7 is an instrument that measures air pressure at sea level. It consists of a thin-walled metal box from which most of the air has been pumped and a dial indicating low- and high-pressure measurements. A pointer on the dial is connected to the box by a lever system. If the pressure of the atmosphere increases, it squeezes the sides of the box. This squeeze causes the pointer to move toward the high-pressure end of the dial. If the pressure decreases, the sides of the box expand outward. That causes the pointer to move toward the low-pressure end of the dial. Notice that the numbers on the dial are from 27 to 31. This scale of numbers is used because average sea level pressure is 29.92 inches and readings below 27 inches or above 31 inches are rarely seen.

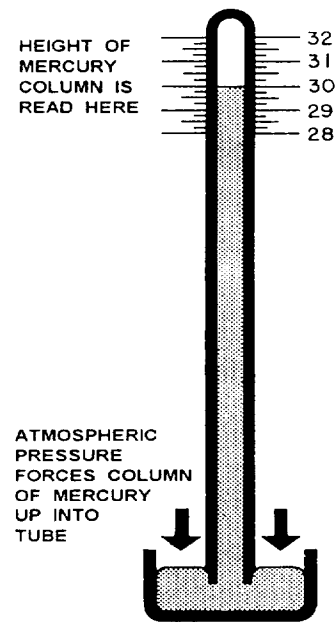

Figure 9-8.-A mercurial barometer.

Mercurial Barometer

Figure 9-8 illustrates a mercurial barometer. It consists of a glass tube on which measurements are indicated; the tube is partially filled with mercury. The upper end, which is closed, contains a vacuum above the mercury. The lower end, which is open, is submerged in a cup of mercury that is open to the atmosphere. The atmosphere presses down on the mercury in the cup and pushes the mercury up in the tube. The greater the air pressure, the higher the rise of mercury within the tube. At sea level, the normal pressure is 14.7 psi, and the height of the mercury in the tube is 30 inches. As the air pressure increases or decreases from day to day, the height of the mercury rises or falls. A mercury barometer aboard ship mounts in gimbals to keep it in a vertical position despite the rolling and pitching of the ship.

The dial of most gauges indicate relative pressure; that is, it is either greater or less than normal. Remember-the dial of an aneroid barometer always indicates absolute pressure, not relative. When the pressure exerted by any gas is less than 14.7 psi, you have what we call a partial vacuum.

Manometer

The condensers on steam turbines operate at a pressure well below 14.7 psi. Steam under high pressure

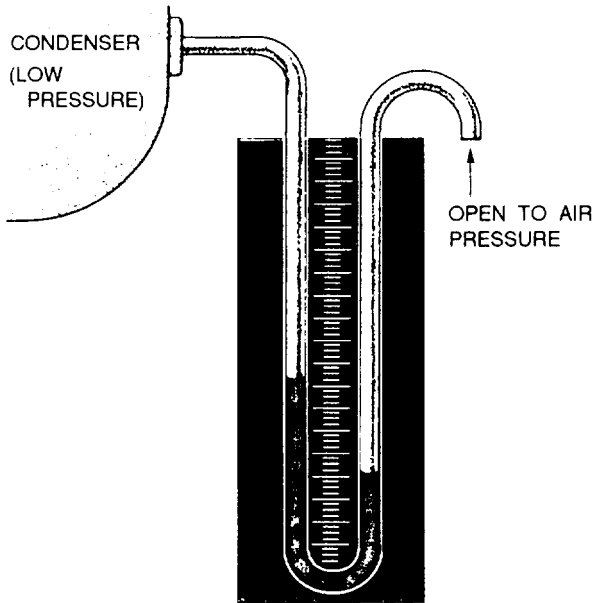

Figure 9-9.-A manometer.

runs into the turbine and causes the rotor to turn. After it has passed through the turbine, it still exerts a back pressure against the blades. If the back pressure were not reduced, it would build until it became as great as that of the incoming steam and prevent the turbine from turning at all. Therefore, the exhaust steam is run through pipes surrounded by cold sea water to reduce the back pressure as much as possible. The cold temperature causes the steam in the pipes to condense into water, and the pressure drops well below atmospheric pressure.

The engineer needs to know the pressure in the condensers at all times. To measure this reduced pressure, or partial vacuum, the engineer uses a gauge called a manometer. As shown in figure 9-9, it consists

of a U-shaped tube. One end is connected to the low-pressure condenser, and the other end is open to the air. The tube is partially filled with colored water. The normal air pressure against the colored water is greater than the low pressure of the steam from the condenser. Therefore, the colored water is forced part of the way into the left arm of the tube. A scale between the two arms of the U indicates the difference in the height of the two columns of water. This difference tells the engineer the degree of vacuum—or how much below atmospheric pressure the pressure within the condenser is.

SUMMARY

You should remember seven points about force and pressure:

A force is a push or a pull exerted on or by an object.

You measure force in pounds.

Pressure is the force per unit area exerted on an object or exerted by an object. You measure it in pounds per square inch (psi).

You calculate pressure by the formula $P = \frac{F}{A}$.

Spring scales and lever balances are familiar instruments you use for measuring forces. Bourdon gauges, barometers, and manometers are instruments for the measurement of pressure.

The normal pressure of the air is 14.7 psi at sea level.

Pressure is generally relative; that is, it is sometimes greater—sometimes less—than normal air pressure. Pressure that is less than the normal air pressure is called a vacuum.

CHAPTER 10

HYDROSTATIC AND HYDRAULIC MACHINES

CHAPTER LEARNING OBJECTIVES

Upon completion of this chapter, you will be able to do the following:

- *Explain the difference between hydrostatic and hydraulic liquids.*
- *Discuss the uses of hydrostatic machines.*
- *Discuss the uses of hydraulic machines.*

In this chapter we will discuss briefly the pressure of liquids: (1) hydrostatic (liquids at rest) and (2) hydraulic (liquids in motion). We will discuss the operation of hydrostatic and hydraulic machines and give applications for both types.

HYDROSTATIC PRESSURE

You know that liquids exert pressure. The pressure exerted by seawater, or by any liquid at rest, is known as hydrostatic pressure.

If you are billeted on a submarine, you are more conscious of the hydrostatic pressure of seawater. When submerged, your submarine is squeezed from all sides by this pressure. A deep-sea diving submarine must be able to withstand the terrific force of water at great depths. Therefore, the air pressure within it must be equal to the hydrostatic pressure surrounding it.

PRINCIPLES OF HYDROSTATIC PRESSURE

In chapter 9 you found out that all fluids exert pressure in all directions. That's simple enough. How great is the pressure? Try a little experiment. Place a pile of blocks in front of you on the table. Stick the tip of your finger under the first block from the top. Not much pressure on your finger, is there? Stick it between the third and fourth blocks. The pressure on your finger has increased. Now slide your finger under the bottom block in the pile. There you will find the pressure is greatest. The pressure increases as you go lower in the pile. You might say that pressure increases with depth. The same

is true in liquids. The deeper you go, the greater the pressure becomes. However, depth isn't the whole story.

Suppose the blocks in the preceding paragraph were made of lead. The pressure at any level in the pile would be considerably greater. Or suppose they were blocks of balsa wood—then the pressure at each level wouldn't be as great. Pressure, then, depends not only on the depth, but also on the weight of the material. Since you are dealing with pressure—force per unit of area, you will also be dealing with weight per unit of volume—or density.

When you talk about the density of a substance, you are talking about its weight per cubic foot or per cubic inch. For example, the density of water is 62.5 pounds per cubic foot; the density of lead is 710 pounds per cubic foot. However, to say that lead is heavier than water isn't a true statement. For instance, a 22-caliber bullet is the same density as a pail of water, but the pail of water is much heavier. It is true, however, that a cubic foot of lead is much heavier than a cubic foot of water.

Pressure depends on two principles—depth and density. You can easily find the pressure at any depth in any liquid by using the following formula:

$$P = H \times D$$

in which

P = pressure, in lb per sq in. or lb per sq ft

H = depth of the point, measured in feet or inches

and

D = density in lb per cu in. or lb per cu ft

Note: If you use inches in your computation, you must use them throughout; if you use feet, you must use them throughout.

What is the pressure on 1 square foot of the surface of a submarine if the submarine is 200 feet below the surface? Using the formula:

$$P = H \times D$$

$$P = 200 \times 62.5 = 12,500 \text{ lb per sq ft}$$

Every square foot of the sub's surface that is at that depth has a force of more than 6 tons pushing in on it. If the height of the hull is 20 feet and the area in question is between the sub's top and bottom, you can see that the pressure on the hull will be at least $(200 - 10) \times 62.5 = 11,875$ pounds per square foot. The greatest pressure will be $(200 + 10) \times 62.5 = 13,125$ pounds per square foot. Obviously, the hull has to be very strong to withstand such pressures.

USES OF HYDROSTATIC PRESSURE

Various shipboard operations depend on the use of hydrostatic pressure. For example, in handling depth charges, torpedoes, mines, and some types of aerial bombs, you'll be dealing with devices that operate by hydrostatic pressure. In addition, you'll deal with hydrostatic pressure in operations involving divers.

Firing Depth Charges

Hiding below the surface exposes the submarine to great fluid pressure. However, it also gives the sub a great advantage because it is hard to hit and, therefore, hard to kill. A depth charge must explode within 30 to 50 feet of a submarine to cause damage. That means the depth charge must not go off until it has had time to sink to approximately the same level as the sub. Therefore, you use a firing mechanism that is set off by the pressure at the estimated depth of the submarine.

Figure 10-1 shows a depth charge and its interior components. A depth charge is a sheet-metal container filled with a high explosive and a firing device. A tube passes through its center from end to end. Fitted in one end of this tube is the booster, a load of granular TNT that sets off the main charge. It is also fitted with a safety fork and an inlet valve cover. Upon launching, the safety fork is knocked off, and the valve cover is removed to allow water to enter.

When the depth charge gets about 12 to 15 feet below the surface, the water pressure is sufficient to extend a bellows in the booster extender. The bellows

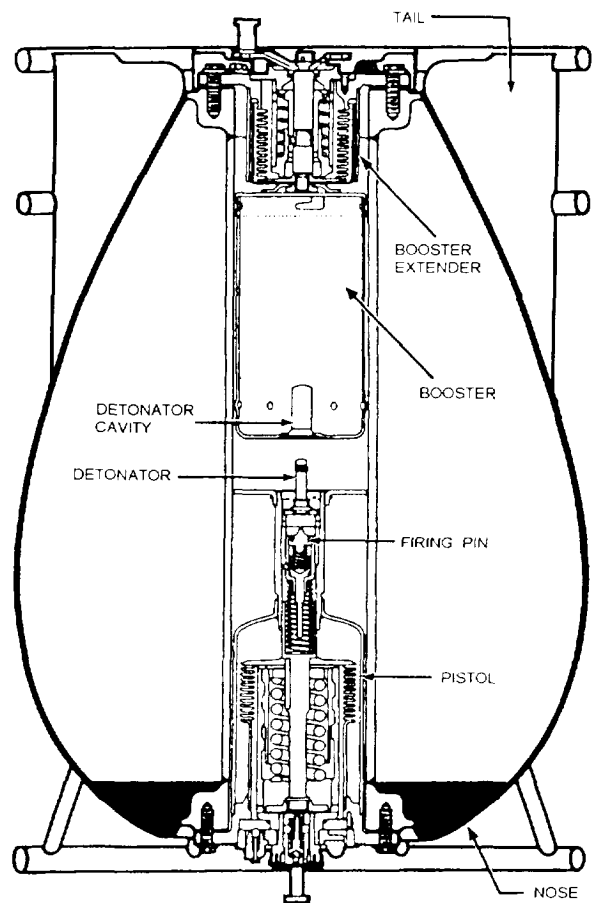

Figure 10-1.-A depth charge.

trips a release mechanism, and a spring pushes the booster up against the centering flange. Notice that the detonator fits into a pocket in the booster. Unless the detonator is in this pocket, it cannot set off the booster charge.

Nothing further happens until the detonator fires. As you can see, the detonator fits into the end of the pistol, with the firing pin aimed at the detonator base. The pistol also contains a bellows into which the water rushes as the charge goes down. As the pressure increases, the bellows begins to expand against the depth spring. You can adjust this spring so that the bellows will have to exert a predetermined force to compress it.

Figure 10-2 shows you the depth-setting dials of one type of depth charge. Since the pressure on the bellows depends directly on the depth, you can select any depth on the dial at which you wish the charge to go off. When the pressure in the bellows becomes sufficiently great, it releases the firing spring, which drives the firing pin

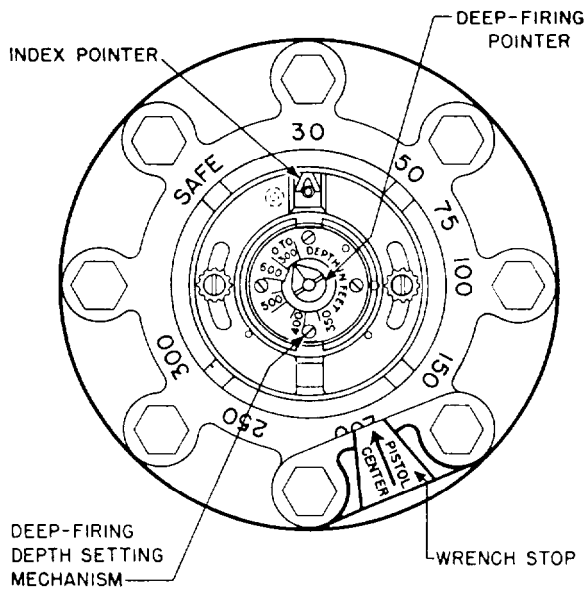

Figure 10-2.-Depth-setting dial.

into the detonator. The booster, already in position, then fires and, in turn, sets off the entire load of TNT.

These two bellows—operated by hydrostatic pressure—serve two purposes. First, they permit the depth charge to fire at the proper depth; second, they make the charge safe to handle and carry. If you should accidentally knock the safety fork and the valve inlet cover off on deck, nothing would happen. Even if the detonator should go off while you were handling the charge, the main charge would not fire unless the booster was in the extended position.

Guiding Torpedoes

To keep a torpedo on course toward its target is a job. Maintaining the proper compass course with a gyroscope is only part of the problem. The torpedo must travel at the proper depth so that it will neither pass under the target ship nor hop out of the water on the way.

As figure 10-3 shows, the torpedo contains an air-filled chamber sealed with a thin, flexible metal plate, or diaphragm. This diaphragm can bend upward or downward against the spring. You determine the spring tension by setting the depth-adjusting knob.

Suppose the torpedo starts to dive below the selected depth. The water, which enters the torpedo and surrounds the chamber, exerts an increased pressure on the diaphragm and causes it to bend down. If you follow the lever system, you can see that the pendulum will push forward. Notice that a valve rod connects the

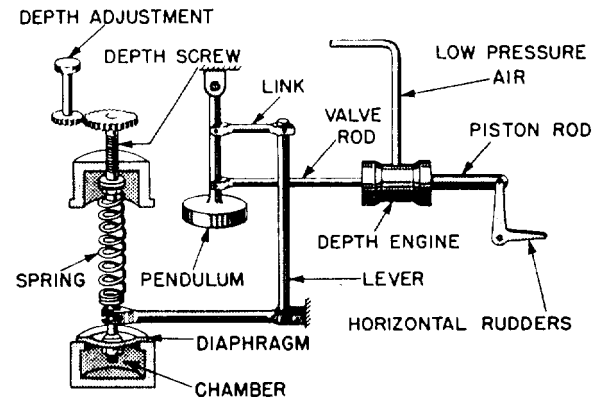

Figure 10-3.-Inside a torpedo.

pendulum to the piston of the depth engine. As the piston moves to the left, low-pressure air from the torpedo's air supply enters the depth engine to the right of the piston and pushes it to the left. You must use a depth engine because the diaphragm is not strong enough to move the rudders.

The piston of the depth engine connects to the horizontal rudders as shown. When the piston moves to the left, the rudder turns upward and the torpedo begins to rise to the proper depth. If the nose goes up, the pendulum swings backward and keeps the rudder from elevating the torpedo too rapidly. As long as the torpedo runs at the selected depth, the pressure on the chamber remains constant and the rudders do not change from their horizontal position.

Diving

Navy divers have a practical, first-hand knowledge of hydrostatic pressure. Think what happens to divers who go down 100 feet to work on a salvage job. The pressure on them at that depth is 8,524 pounds per square foot! Something must be done about that, or they would be flatter than a pancake.

To counterbalance this external pressure, a diver wears a rubber suit. A shipboard compressor then pumps pressurized air into the suit, which inflates it and provides oxygen to the diver's body as well. The oxygen enters the diver's lungs and bloodstream, which carries it to every part of the body. In that way the diver's internal pressure is equal to the hydrostatic pressure.

As the diver goes deeper, the air pressure increases to meet that of the water. In coming up, the pressure on the air is gradually reduced. If brought up too rapidly, the diver gets the "bends." That is, the air that was dissolved in the blood begins to come out of solution

and form bubbles in the veins. Any sudden release in the pressure on a fluid results in the freeing of some gases that are dissolved in the fluid. You have seen this happen when you suddenly relieve the pressure on a bottle of pop by removing the cap. The careful matching of hydrostatic pressure on the diver by air pressure in the diving suit is essential if diving is to be done at all.

Determining Ship's Speed

Did you ever wonder how the skipper knows the speed the ship is making through water? The skipper can get this information by using several instruments—the patent log, the engine revolution counter, and the pitometer (pit) log. The “pit log” operates, in part, by hydrostatic pressure. It really shows the difference between hydrostatic pressure and the pressure of the water flowing past the ship—but this difference can be used to find ship's speed.

Figure 10-4 shows a schematic drawing of a pitometer log. It consists of a double-wall tube that sticks out forward of the ship's hull into water that is not disturbed by the ship's motion. In the tip of the tube is an opening (A). When the ship is moving, two forces or pressures are acting on this opening: (1) the hydrostatic pressure caused by the depth of the water above the opening and (2) a pressure caused by the push of the ship through the water. The total pressure from these two forces transmits through the central tube (shown in white on the figure) to the left-hand arm of a manometer.

In the side of the tube is a second opening (B) that does not face the direction in which the ship is moving. Opening B passes through the outer wall of the double-wall tube, but not through the inner wall. The only pressure affecting opening B is the hydrostatic

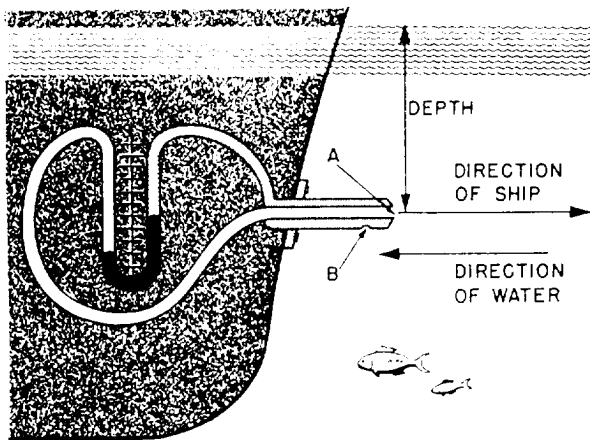

figure 10-4.-A pitometer log.

pressure. This pressure transmits through the outer tube (shaded in the drawing) to the right-hand arm of the manometer.

When the ship is dead in the water, the pressure through both openings A and B is the same, and the mercury in each arm of the manometer stands at the same level. However, as soon as the ship begins to move, additional pressure develops at opening A, and the mercury pushes down in the left-hand arm and up into the right-hand arm of the tube. The faster the ship goes, the greater this additional pressure becomes, and the greater the difference will be between the levels of the mercury in the two arms of the manometer. You can read the speed of the ship directly from the calibrated scale on the manometer.

Since air is also a fluid, the airspeed of an aircraft can be found by a similar device. You have probably seen the thin tube sticking out from the nose or the leading edge of a wing of the plane. Flyers call this tube a pitot tube. Its basic principle is the same as that of the pitometer log.

HYDRAULIC PRESSURE

Perhaps your earliest contact with hydraulic pressure was when you got your first haircut. The hairdresser put a board across the arms of the chair, sat you on it, and began to pump the chair up to a convenient level. As you grew older, you probably discovered that the gas station attendant could put a car on the greasing rack and—by some mysterious arrangement—jack it head high. The attendant may have told you that oil under pressure below the piston was doing the job.

Come to think about it, you've probably known something about hydraulics for a long time. Automobiles and airplanes use hydraulic brakes. As a sailor, you'll have to operate many hydraulic machines. You'll want to understand the basic principles on which they work.

Primitive man used simple machines such as the lever, the inclined plane, the pulley, the wedge, and the wheel and axle. It was considerably later before someone discovered that you could use liquids and gases to exert forces at a distance. Then, a vast number of new machines appeared. A machine that transmits forces by a liquid is a hydraulic machine. A variation of the hydraulic machine is the type that operates with a compressed gas. This type is known as the pneumatic machine. This chapter deals only with basic hydraulic machines.

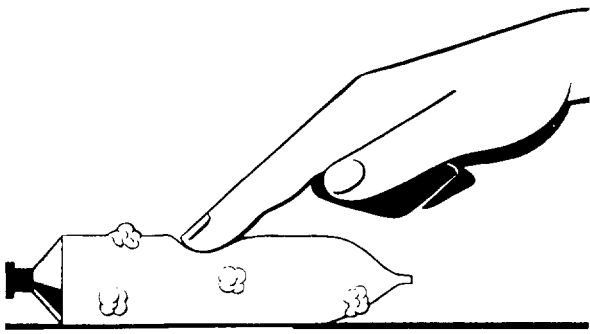

Figure 10-5.-Pressure to a fluid transmits in all directions.

PRINCIPLES OF HYDRAULIC PRESSURE

A Frenchman named Pascal discovered that a pressure applied to any part of a confined fluid transmits to every other part with no loss. The pressure acts with equal force on all equal areas of the confining walls and perpendicular to the walls.

Remember when you are talking about the hydraulic machine, you are talking about the way a liquid acts in a closed system of pipes and cylinders. The action of a liquid under such conditions is somewhat different from its behavior in open containers or in lakes, rivers, or oceans. You also should keep in mind that you cannot compress most liquids into a smaller space. Liquids don't "give" the way air does when you apply pressure, nor do liquids expand when you remove pressure.

Punch a hole in a tube of toothpaste. If you push down at any point on the tube, the toothpaste comes out of the hole. Your force has transmitted from one place to another through the toothpaste, which is a thick, liquid fluid. Figure 10-5 shows what would happen if you punched four holes in the tube. If you were to press on the tube at one point, the toothpaste would come out of all four holes. You have illustrated a basic principle of hydraulic machines. That is, a force applied on a liquid transmits equally in every direction to all parts of the container.

We use this principle in the operation of four-wheel hydraulic automobile brakes. Figure 10-6 is a simplified drawing of this brake system. You push down on the brake pedal and force the piston in the master cylinder against the fluid in that cylinder. This push sets up a pressure on the fluid as your finger did on the toothpaste in the tube. The pressure on the fluid in the master cylinder transmits through the lines to the brake cylinders in each wheel. This fluid under pressure

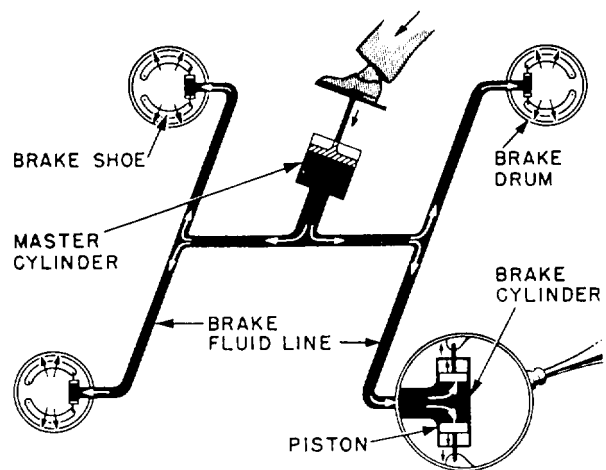

Figure 10-6.-Hydraulic brakes.

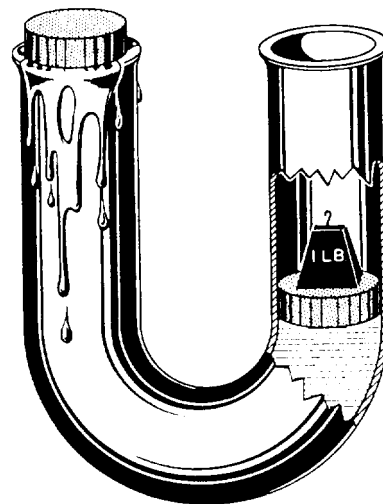

Figure 10-7.-Liquid transmits force.

pushes against the pistons in each of the brake cylinders and forces the brake shoes out against the drums.

MECHANICAL ADVANTAGES OF HYDRAULIC PRESSURE

Another aspect to understand about hydraulic machines is the relationship between the force you apply and the result you get. Figure 10-7 will help you understand this principle. The U-shaped tube has a cross-sectional area of 1 square inch. In each arm is a piston that fits snugly, but can move up and down. If you place a 1-pound weight on one piston, the other one will push out the top of its arm immediately. If you place a

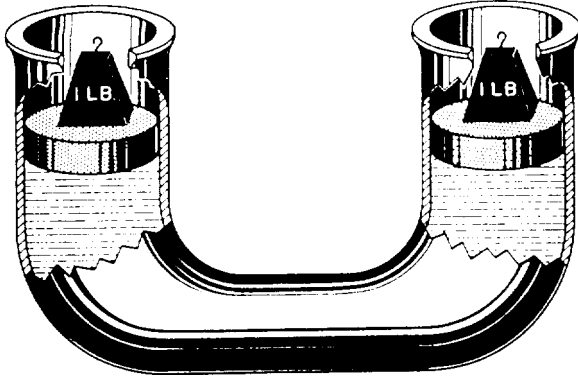

Figure 10-8.-Equal pressure applied at each end of a tube containing a liquid.

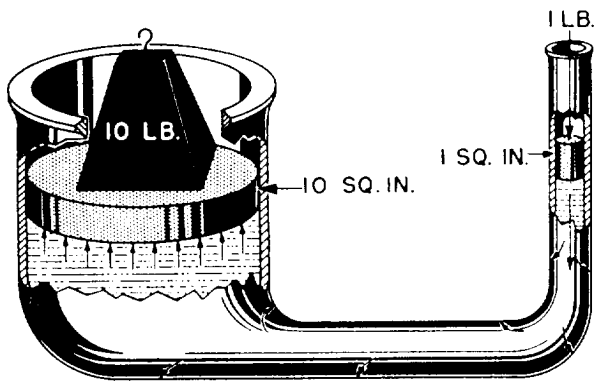

Figure 10-9.-A mechanical advantage of 10.

1-pound weight on each piston, however, each one will remain in its original position, as shown in figure 10-8.

Thus, you see that a pressure of 1 pound per square inch applied downward on the right-hand piston exerts a pressure of 1 pound per square inch upward against the left-hand one. Not only does the force transmit through the liquid around the curve, it transmits equally on each unit area of the container. It makes no difference how long the connecting tube is or how many turns it makes. It is important that the entire system be full of liquid. Hydraulic systems will fail to operate properly if air is present in the lines or cylinders.

Now look at figure 10-9. The piston on the right has an area of 1 square inch, but the piston on the left has an area of 10 square inches. If you push down on the smaller piston with a force of 1 pound, the liquid will transmit this pressure to every square inch of surface in the system. Since the left-hand piston has an area of 10 square inches, each square inch has a force of 1 pound

transmitted to it. The total effect is a push on the larger piston with a total force of 10 pounds. Set a 10-pound weight on the larger piston and it will support the 1-pound force of the smaller piston. You then have a 1-pound push resulting in a 10-pound force. That's a mechanical advantage of 10. This mechanical advantage is why hydraulic machines are important.

Here's a formula that will help you to figure the forces that act in a hydraulic machine:

$$\frac{F_1}{F_2} = \frac{A_1}{A_2}$$

In that,

F_1 = force, in pounds, applied to the small piston;

F_2 = force, in pounds, applied to the large piston;

A_1 = area of the small piston, in square inches; and

A_2 = area of the large piston, in square inches.

Let's apply the formula to the hydraulic press shown in figure 10-10. The large piston has an area of 90 square inches, and the smaller one has an area of 2 square inches. The handle exerts a total force of 15 pounds on the small piston. With what total force could you raise the large piston?

Write down the formula

$$\frac{F_1}{F_2} = \frac{A_1}{A_2}$$

Substitute the known values

$$\frac{15}{F_2} = \frac{2}{90}$$

and

$$F_2 = \frac{90 \times 15}{2} = 675 \text{ pounds.}$$

USES OF HYDRAULIC PRESSURE

You know from your experience with levers that you can't get something for nothing. Applying this knowledge to the simple system in figure 10-9, you know that you can't get a 10-pound force from a

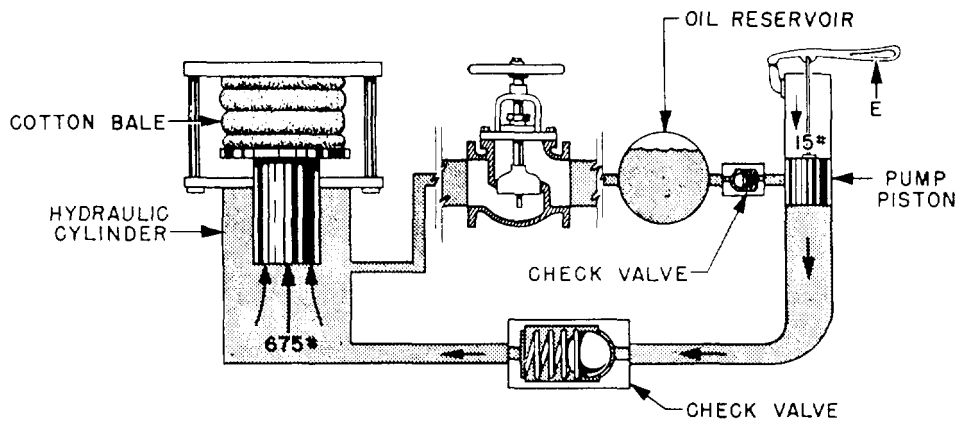

Figure 10-10.-Hydraulic press.

1-pound effort without sacrificing distance. You must apply the 1-pound effort through a much greater distance than the 10-pound force will move. To raise the 10-pound weight a distance of 1 foot, you must apply the 1-pound effort through what distance? Remember, if you neglect friction, the work done on any machine equals the work done by that machine. Use the work formula to find how far the smaller piston will have to move.

Work input = Work output

$$F_1 \times D_1 = F_2 \times D_2$$

By substituting

$$1 \times D_1 = 10 \times 1$$

you find that

$$D_1 = 10 \text{ feet}$$

The smaller piston will have to move a distance of 10 feet to raise the 10-pound load 1 foot. It looks then as though the smaller cylinder would have to be at least 10 feet long—and that wouldn't be practical. In addition, it isn't necessary if you put a valve in the system.

The hydraulic press in figure 10-10 contains a valve. As the small piston moves down, it forces the fluid past check valve A into the large cylinder. As soon as the small piston moves upward, it removes the pressure to the right of check valve A. The pressure of the fluid on the check valve spring below the large piston helps force

that valve shut. The liquid that has passed through the valve opening on the down stroke of the small piston is trapped in the large cylinder.

The small piston rises on the upstroke until its bottom passes the opening to the fluid reservoir. More fluid is sucked past check valve B and into the small cylinder. The next downstroke forces this new charge of fluid out of the small cylinder past the check valve into the large cylinder. This process repeats stroke by stroke until enough fluid has been forced into the large cylinder to raise the large piston the required distance of 1 foot. The force has been applied through a distance of 10 feet on the pump handle. However, it was done through a series of relatively short strokes, the total of the strokes being equal to 10 feet.

Maybe you're beginning to wonder how the large piston gets back down after the process is finished. The fluid can't run back past check valve B—that's obvious. Therefore, you lower the piston by letting the oil flow back into the reservoir through a return line. Notice that a simple globe valve is in this line. When the globe valve opens, the fluid flows back into the reservoir. Of course, this valve is shut while the pump is in operation.

Aiding the Helmsman

You've probably seen the helmsman swing a ship weighing thousands of tons almost as easily as you turn your car. No, helmsmen are not superhuman. They control the ship with machines. Many of these machines are hydraulic.

There are several types of hydraulic and electro-hydraulic steering mechanisms. The simplified diagram

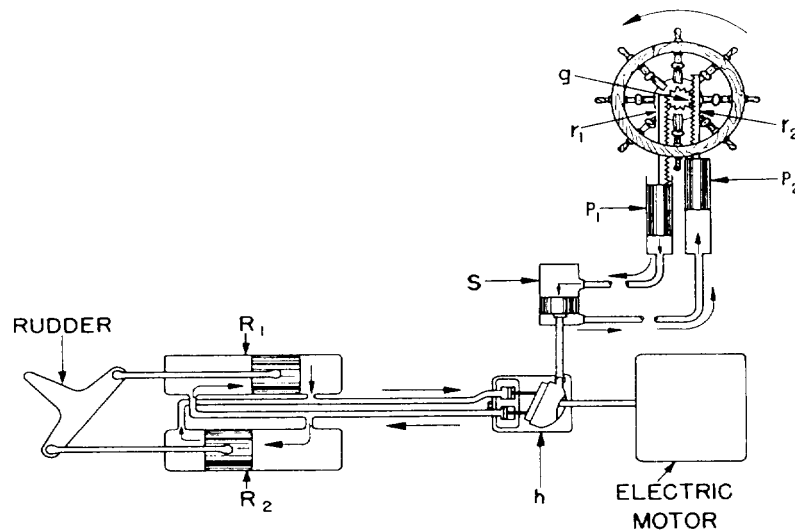

Figure 10-11.-Electrohydraulic steering mechanism.

in figure 10-11 will help you to understand the general principles of their operation. As the hand steering wheel turns in a counterclockwise direction, its motion turns the pinion gear (g). This causes the left-hand rack (r_1) to move downward and the right-hand rack (r_2) to move upward. Notice that each rack attaches to a piston (p_1 or p_2). The downward motion of rack r_1 moves piston p_1 downward in its cylinder and pushes the oil out of that cylinder through the line. At the same time, piston p_2 moves upward and pulls oil from the right-hand line into the right-hand cylinder.

If you follow these two lines, you see that they enter a hydraulic cylinder (S). One line enters above and one below the single piston in that cylinder. This piston and the attached plunger are pushed down toward the hydraulic pump (h) in the direction of the oil flow shown in the diagram. So far in this operation, hand power has been used to develop enough oil pressure to move the control plunger attached to the hydraulic pump. At this point, an electric motor takes over and drives the pump (h).

Oil is pumped under pressure to the two big steering rams (R_1 and R_2). You can see that the pistons in these rams connect directly to the rudder crosshead that controls the position of the rudder. With the pump operating in the direction shown, the ship's rudder is thrown to the left, and the bow will swing to port. This operation shows how a small force applied on the steering wheel sets in motion a series of operations that result in a force of thousands of pounds.

Getting Planes on Deck

The swift, smooth power required to get airplanes from the hanger deck to the flight deck of a carrier is provided by a hydraulic lift. Figure 10-12 shows how this lifting is done. An electric motor drives a variable-speed gear pump. Oil enters the pump from the reservoir and is forced through the lines to four hydraulic rams. The pistons of the rams raise the elevator platform. The oil under pressure exerts its force on each square inch of surface area of the four pistons. Since the pistons are large, a large total lifting force results. Either reversing the pump or opening valve 1 and closing valve 2 lowers the elevator. The weight of the elevator then forces the oil out of the cylinders and back into the reservoir.

Operating Submarines

Another application of hydraulics is the operation of submarines. Inside a submarine, between the outer skin and the pressure hull, are several tanks of various design and purpose. These tanks control the total weight of the ship, allowing it to submerge or surface. They also control the trim or balance, fore and aft, of the submarine. The main ballast tanks have the primary function of either destroying or restoring positive buoyancy to the submarine. Allowing air to escape through hydraulically operated vents at the top of the tanks lets seawater enter through the flood ports at the bottom to replace the air. For the sub to regain positive buoyancy, the tanks are "blown" free of seawater with

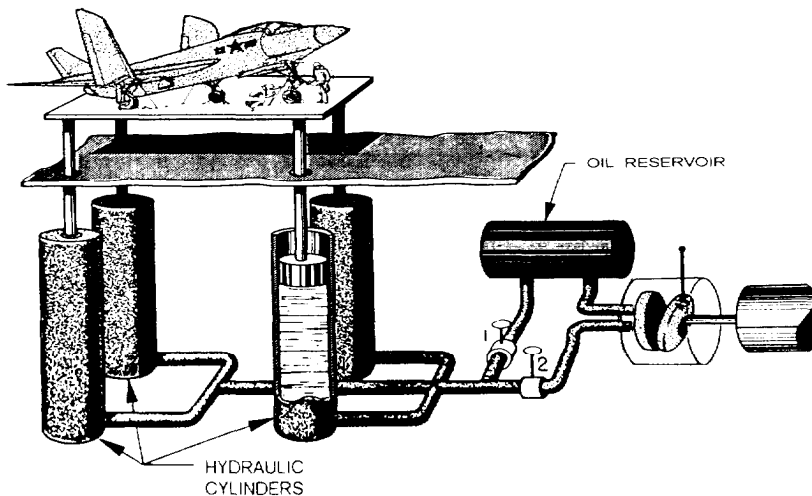

Figure 10-12.-Hydraulic lift.

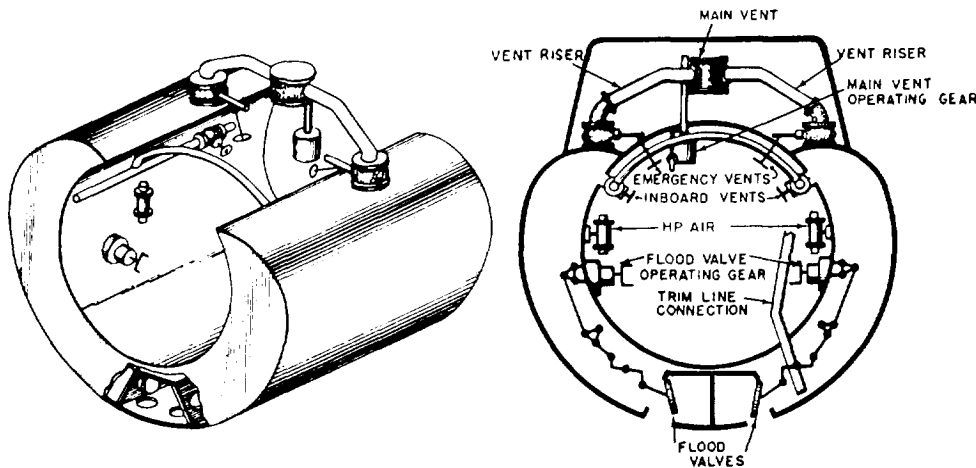

Figure 10-13.-Submarine special ballast tank (safety tank).

compressed air. Sufficient air is left trapped in the tanks to prevent the seawater from reentering.

We use other tanks, such as variable ballast tanks and special ballast tanks (for example, the negative tank, safety tank, and bow buoyancy tank), either for controlling trim or stability or for emergency weight-compensating purposes. The variable ballast tanks have no direct connection to the sea. Therefore, we must pump water into or out of them. The negative tank and the safety tank can open to the sea through large flood valves. These valves, as well as the vent valves for the main ballast tanks and those for the safety and negative tanks, are all hydraulically operated.

The vents and flood valves are outside the pressure hull, so some means of remote control is needed to open

and close them from within the submarine. We use hydraulic pumps, lines, and rams for this purpose. Oil pumped through tubing running through the pressure hull actuates the valve's operating mechanisms by exerting pressure on and moving a piston in a hydraulic cylinder. Operating the valves by a hydraulic system from a control room is easier and simpler than doing so by a mechanical system of gears, shafts, and levers. The hydraulic lines can be readily led around corners and obstructions, and a minimum of moving parts is required.

Figure 10-13 is a schematic sketch of the safety tank-one of the special ballast tanks in a submarine. The main vent and the flood valves of this tank operate

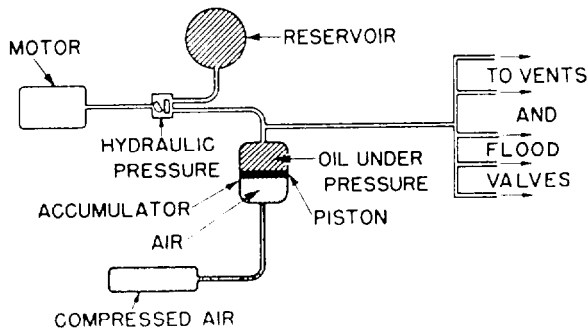

Figure 10-14.-Controlling fluid pressure.

hydraulically by remote control, although in an emergency they may operate manually.

Hydraulics are used in many other ways aboard submarines. They are used to raise and lower the periscope. The submarines are steered and the bow and stern planes are controlled by hydraulic systems. The windlass and capstan system, used in mooring the submarine, is hydraulically operated. You will find many more applications of hydraulics aboard the submarine.

Controlling Fluid Pressure

In some hydraulic systems, oil is kept under pressure in a container known as an accumulator. As shown in figure 11-14, the accumulator is a large cylinder; oil is pumped into it from the top. A free piston divides the cylinder into two parts. Compressed air is forced into the cylinder below the piston at a pressure of 600 psi. Oil is then forced into it on top of the piston. As the pressure above it increases, the piston is forced down, squeezing the air into a smaller space. Air is elastic; you can compress it under pressure, and it will expand as soon as the pressure is reduced. When oil pressure is reduced, large quantities of oil under working pressure are instantly available to operate hydraulic rams or motors any place on the submarine.

SUMMARY

The Navy uses many devices whose operation depends on the hydrostatic principle. You should remember three points about the operation of these devices:

Pressure in a liquid is exerted equally in all directions.

Hydrostatic pressure refers to pressure at any depth in a liquid that is not flowing.

Pressure depends upon both depth and density.

The formula for finding pressure is

$$P = H \times D$$

The working principle of all hydraulic mechanisms is simple enough. Whenever you find an application that seems hard to understand, keep these points in mind:

Hydraulics is the term applied to the behavior of enclosed liquids. Machines that operate liquids under pressure are called hydraulic machines.

Liquids are incompressible. They cannot be squeezed into spaces smaller than they originally occupied.

A force applied on any area of a confined liquid transmits equally to every part of that liquid.

In hydraulic cylinders, the relation between the force exerted by the large piston to the force applied on the smaller piston is the same as the relationship between the area of the larger piston and the area of the smaller piston.

Some of the advantages of hydraulic machines are:

We use tubing to transmit forces, and tubing can readily transmit forces around corners.

Tubing requires little space.

Few moving parts are required.

CHAPTER 11**MACHINE ELEMENTS AND BASIC MECHANISMS****CHAPTER LEARNING OBJECTIVES**

Upon completion of this chapter, you should be able to do the following:

- *Describe the machine elements used in naval machinery and equipment.*
 - *Identify the basic machines used in naval machinery and equipment.*
 - *Explain the use of clutches.*
-

Any machine, however simple, consists of one or more basic machine elements or mechanisms. In this chapter we will take a look at some of the more familiar elements and mechanisms used in naval machinery and equipment.

BEARINGS

Friction is the resistance of force between two surfaces. In chapter 7 we saw that two objects rubbing against each other produce friction. If the surfaces are smooth, they produce little friction; if either or both are rough, they produce more friction. To start rolling a loaded hand truck across the deck, you would have to give it a hard tug to overcome the resistance of static friction. To start sliding the same load across the deck, you would have to give it an even harder push. That is because rolling friction is always less than sliding friction. We take advantage of this fact by using rollers or bearings in machines to reduce friction. We use lubricants on bearing surfaces to reduce the friction even further.

A bearing is a support and guide that carries a moving part (or parts) of a machine. It maintains the proper relationship between the moving part or parts and the stationary part. It usually permits only one form of motion, such as rotation. There are two basic types of bearings: sliding (plain bearings), also called friction or

guide bearings, and antifrictional (roller and ball bearings).

SLIDING BEARINGS

In sliding (plain) bearings, a film of lubricant separates the moving part from the stationary part. Three types of sliding bearings are commonly used: reciprocal motion bearings, journal bearings, and thrust bearings.

Reciprocal Motion Bearings

Reciprocal motion bearings provide a bearing surface on which an object slides back and forth. They are found on steam reciprocating pumps, in which connecting rods slide on bearing surfaces near their connections to the pistons. We use similar bearings on the connecting rods of large internal-combustion engines and in many mechanisms operated by cams.

Journal Bearings

Journal bearings guide and support revolving shafts. The shaft revolves in a housing fitted with a liner. The inside of the liner, on which the shaft bears, is made of babbitt metal or a similar soft alloy (antifriction metal) to reduce friction. The soft metal is backed by a bronze or copper layer and has a steel back for strength. Sometimes the bearing is made in two halves and is

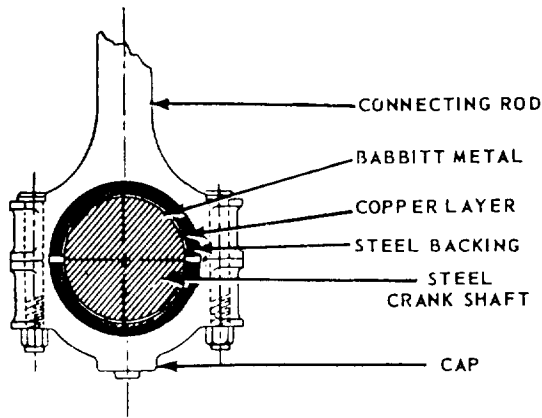

Figure 11-1.-Babbitt-lined bearing in which steel shaft revolves.

clamped or screwed around the shaft (fig. 11-1). We also call it a laminated sleeve bearing.

Under favorable conditions the friction in journal bearings is remarkably small. However, when the rubbing speed of a journal bearing is very low or extremely high, the friction loss may become excessive. A good example is the railroad car. Railroad cars are now being fitted with roller bearings to eliminate the "hot box" troubles associated with journal bearings.

Heavy-duty bearings have oil circulated around and through them. Some have an additional cooling system that circulates water around the bearing. Although revolving the steel shaft against babbitt metal produces less friction (and less heat and wear) than steel against

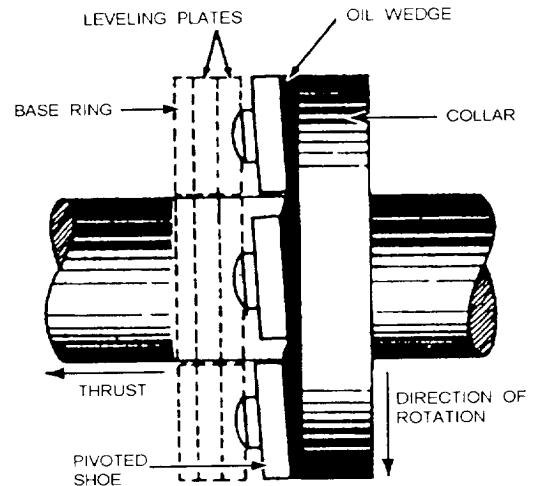

Figure 11-3.-Diagrammatic arrangement of a Kingsbury thrust bearing, showing oil film.

steel, keeping the parts cool is still a problem. The same care and lubrication needed to prevent a burned out bearing on your car is needed on all Navy equipment, only more so. Many lives depend on the continued operation of Navy equipment.

Thrust Bearings

Thrust bearings are used on rotating shafts, such as those supporting bevel gears, worm gears, propellers, and fans. They resist axial thrust or force and limit axial

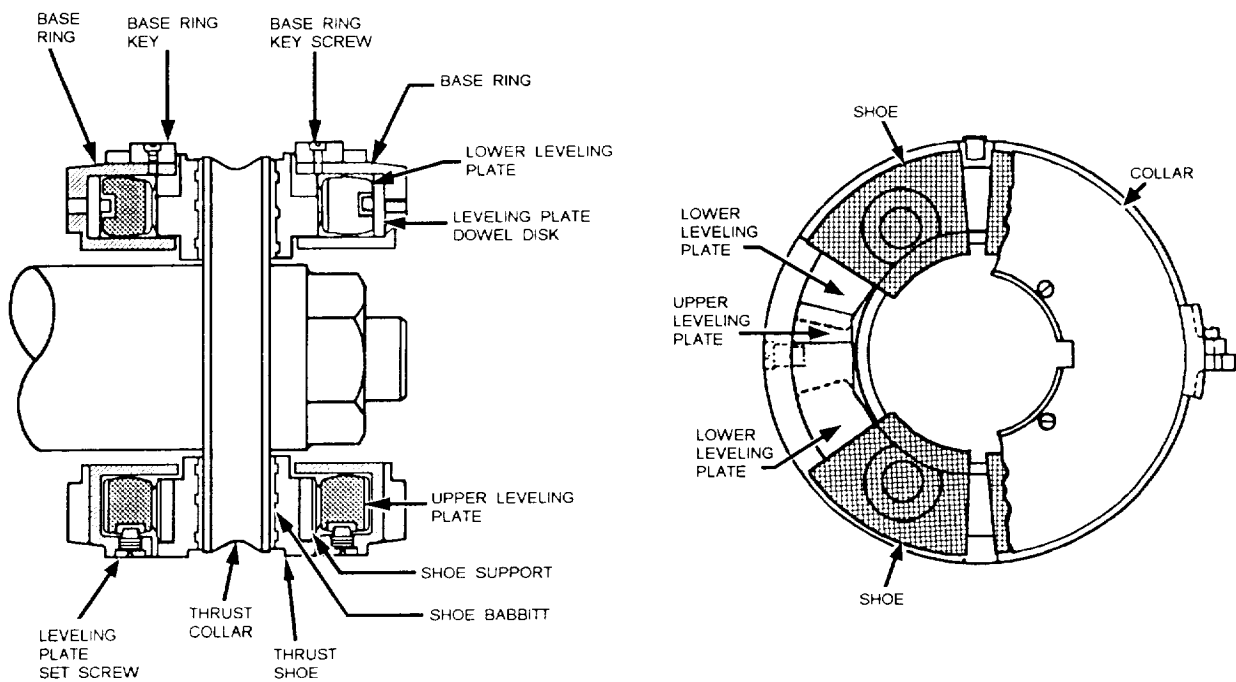

Figure 11-2.-Kingsbury pivoted-shoe thrust bearing.

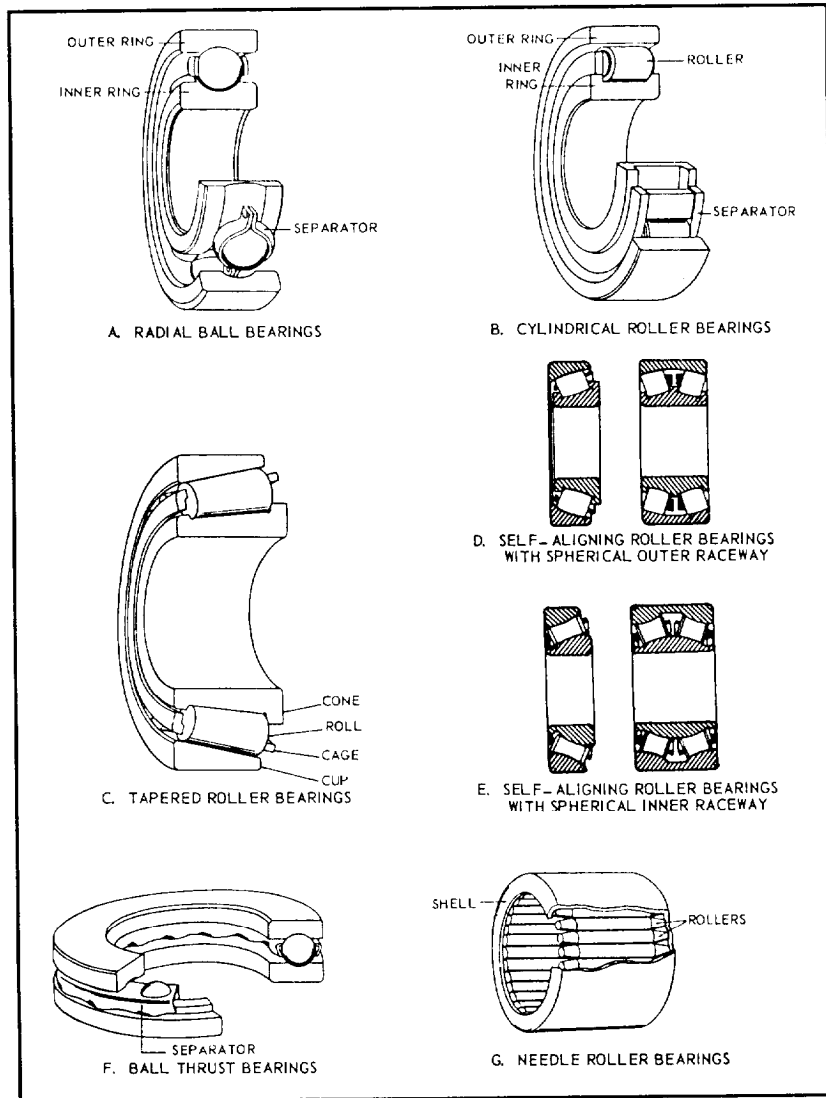

Figure 11-4. The seven basic types of antifrictional bearings.

movement. They are used chiefly on heavy machinery, such as Kingsbury thrust bearings used in heavy marine-propelling machinery (figs. 11-2 and 11-3). The base of the housing holds an oil bath, and the rotation of the shaft continually distributes the oil. The bearing consists of a thrust collar on the propeller shaft and two or more stationary thrust shoes on either side of the collar. Thrust is transmitted from the collar through the shoes to the gear housing and the ship's structure to which the gear housing is bolted.

ANTIFRICTIONAL OR ROLLER AND BALL BEARINGS

You have had first-hand acquaintance with ball bearings since you were a child. They are what made

your roller skates or bicycle wheels spin freely. If any of the little steel balls came out and were lost, your roller skates screeched and groaned.

Antifrictional balls or rollers are made of hard, highly polished steel. Typical bearings consist of two hardened steel rings (called races), the hardened steel balls or rollers, and a separator. The motion occurs between the race surfaces and the rolling elements. There are seven basic types of antifrictional bearings (fig. 11-4):

1. Radial ball bearings
2. Cylindrical roller bearings
3. Tapered roller bearings

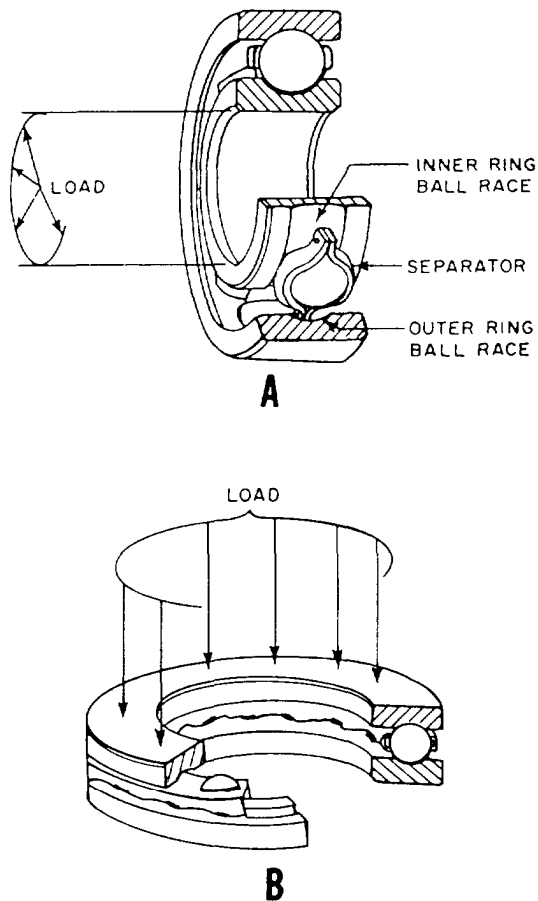

Figure 11-5.-Ball bearings. A. Radial type; B. Thrust type.

4. Self-aligning roller bearings with a spherical outer raceway
5. Self-aligning roller bearings with a spherical inner raceway
6. Ball thrust bearings
7. Needle roller bearings

Roller bearing assemblies are usually easy to disassemble for inspection, cleaning, and replacement of parts. Ball bearings are assembled by the manufacturer and are installed, or replaced, as a unit. Sometimes maintenance publications refer to roller and ball bearings as either thrust or radial bearings. The difference between the two depends on the angle of intersection between the direction of the load and the plane of rotation of the bearing.

Figure 11-5, A, shows a radial ball bearing assembly. The load shown is pressing outward along the radius of the shaft. Now suppose a strong thrust were to be exerted on the right end of the shaft in an effort to

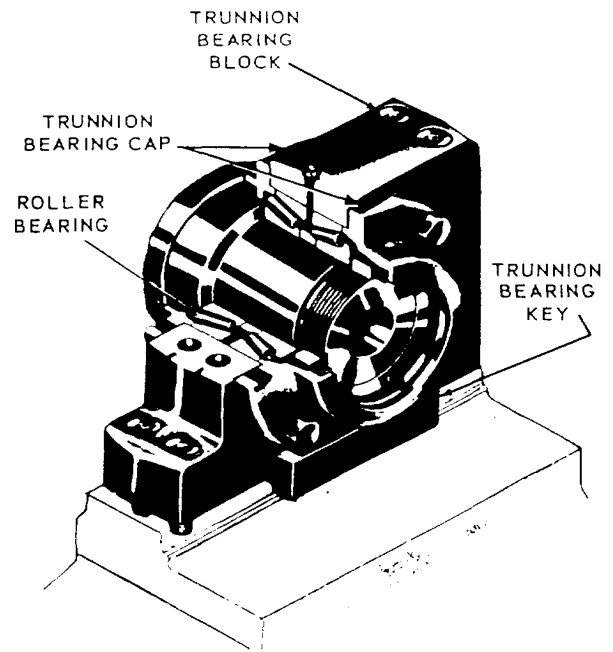

Figure 11-6.-Radial-thrust roller bearing.

move it to the left. You would find that the radial bearing is not designed to support this axial thrust. Even putting a shoulder between the load and the inner race wouldn't support it; instead, the bearings would pop out of their races.

Supporting a thrust on the right end of the shaft would require the thrust bearing arrangement of the braces shown in figure 11-5, B. A shoulder under the lower race and another between the load and the upper race would handle any axial load up to the design limit of the bearing.

Sometimes bearings are designed to support both thrust and radial loads. This explains the use of the term "radial thrust" bearings. The tapered roller bearing in figure 11-6 is an example of a radial-thrust roller bearing.

Antifriction bearings require smaller housings than other bearings of the same load capacity and can operate at higher speeds.

SPRINGS

Springs are elastic bodies (generally metal) that can be twisted, pulled, or stretched by some force. They can return to their original shape when the force is released. All springs used in naval machinery are made of metal—usually steel—though some are made of phosphor bronze, brass, or other alloys. A part that is subject to constant spring thrust or pressure is said to be

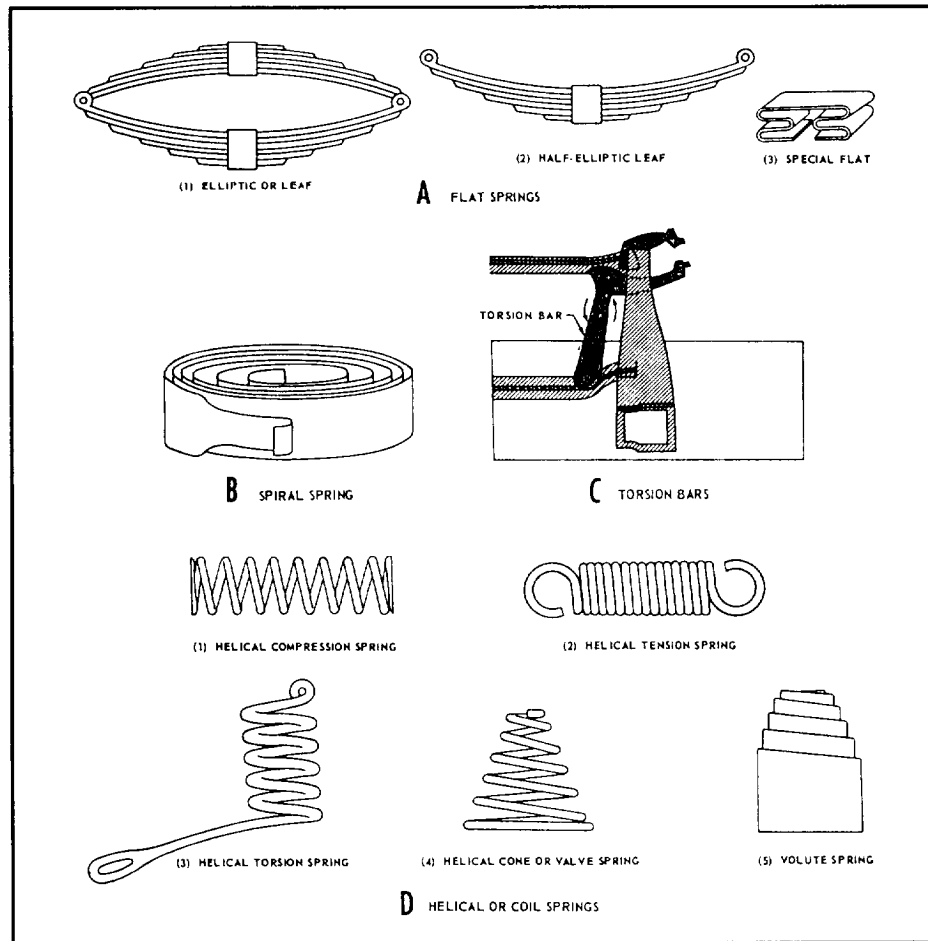

Figure 11-7.-Types of springs.

spring-loaded. (Some components that appear to be spring-loaded are actually under hydraulic or pneumatic pressure or are moved by weights.)

FUNCTIONS OF SPRINGS

Springs are used for many purposes, and one spring may serve more than one purpose. Listed below are some of the more common of these functional purposes. As you read them, try to think of at least one familiar application of each.

1. To store energy for part of a functioning cycle.
2. To force a component to bear against, to maintain contact with, to engage, to disengage, or to remain clear of some other component.
3. To counterbalance a weight or thrust (gravitational, hydraulic, etc.). Such springs are usually called equilibrator springs.
4. To maintain electrical continuity.

5. To return a component to its original position after displacement.
6. To reduce shock or impact by gradually checking the motion of a moving weight.
7. To permit some freedom of movement between aligned components without disengaging them. These are sometimes called take-up springs.

TYPES OF SPRINGS

As you read different books, you will find that authors do not agree on the classification of types of springs. The names are not as important as the types of work they do and the loads they can bear. The three basic types are (1) flat, (2) spiral, and (3) helical.

Flat Springs

Flat springs include various forms of elliptic or leaf springs (fig. 11-7, A [1] and [2]), made up of flat or

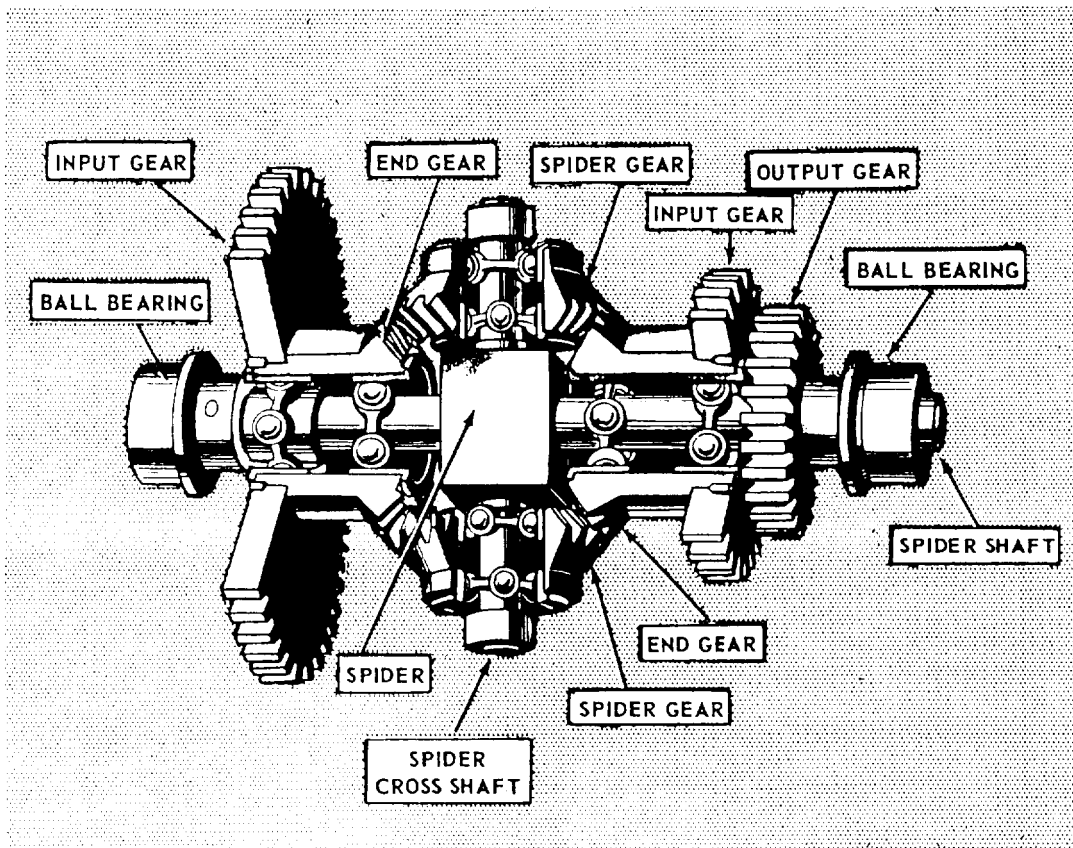

Figure 11-8.-Bevel gear differential.

slightly curved bars, plates, or leaves. They also include special flat springs (fig. 11-7, A [3]), made from a flat strip or bar formed into whatever shape or design best suited for a specific position and purpose.

Spiral Springs

Spiral springs are sometimes called clock, power (1 1-7, B), or coil springs. A well-known example is a watch or clock spring; after you wind (tighten) it, it gradually unwinds and releases power. Although other names for these springs are based on good authority, we call them “spiral” in this text to avoid confusion.

Helical Springs

Helical springs, also often called spiral (fig. 11-7, D), are probably the most common type of spring. They may be used in compression (fig. 11-7, D [1]), extension or tension (fig. 11-7, D [2]), or torsion (fig. 11-7, D [3]). A spring used in compression tends to shorten in action,

while a tension spring lengthens in action. Torsion springs, which transmit a twist instead of a direct pull, operate by a coiling or an uncoiling action.

In addition to straight helical springs, cone, double-cone, keg, and volute springs are classified as helical. These types of springs are usually used in compression. A cone spring (11-7, D [4]), often called a valve spring because it is frequently used in valves, is formed by wire being wound on a tapered mandrel instead of a straight one. A double cone spring (not illustrated) consists of two cones joined at the small ends, and a keg spring (not illustrated) consists of two cone springs joined at their large ends.

Volute springs (fig. 11-7, D [5]) are conical springs made from a flat bar that is wound so that each coil partially overlaps the adjacent one. The width (and thickness) of the material gives it great strength or resistance.

You can press a conical spring flat so that it requires little space, and it is not likely to buckle sidewise.

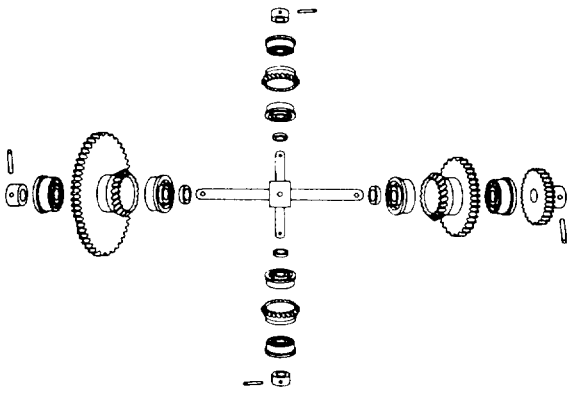

Figure 11-9.-Exploded view of differential gear system.

Other Types of Springs

Torsion bars (fig. 11-7, C) are straight bars that are acted on by torsion (twisting force). The bars may be circular or rectangular in cross section. They also may be tube shaped; other shapes are uncommon.

A special type of spring is a ring spring or disc spring (not illustrated). It is made of several metal rings or discs that overlap each other.

THE GEAR DIFFERENTIAL

A gear differential is a mechanism that is capable of adding and subtracting mechanically. To be more precise, we should say that it adds the total revolutions of two shafts. It also subtracts the total revolutions of one shaft from the total revolutions of another shaft—and delivers the answer by a third shaft. The gear differential will continuously and accurately add or subtract any number of revolutions. It will produce a continuous series of answers as the inputs change.

Figure 11-8 is a cutaway drawing of a bevel gear differential showing all of its parts and how they relate to each other. Grouped around the center of the mechanism are four bevel gears meshed together. The two bevel gears on either side are “end gears.” The two bevel gears above and below are “spider gears.” The long shaft running through the end gears and the three spur gears is the “spider shaft.” The short shaft running through the spider gears together with the spider gears themselves make up the “spider.”

Each spider gear and end gear is bearing-mounted on its shaft and is free to rotate. The spider shaft connects

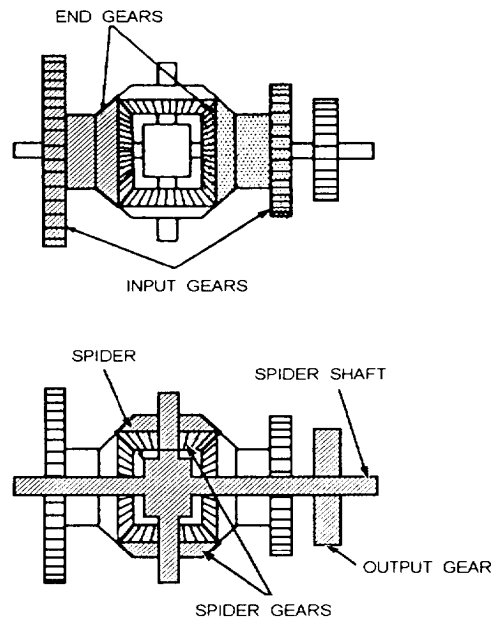

Figure 11-10.-The differential. End gears and spider arrangement.

with the spider cross shaft at the center block where they intersect. The ends of the spider shaft are secured in flanges or hangers. The spider cross shaft and the spider shaft are also bearing-mounted and are free to rotate on their axis. Therefore, since the two shafts are rigidly connected, the spider (consisting of the spider cross shaft and the spider gears) must tumble, or spin, on the axis of the spider shaft.

The three spur gears, shown in figure 11-8, are used to connect the two end gears and the spider shaft to other mechanisms. They may be of any convenient size. Each of the two input spur gears is attached to an end gear. An input gear and an end gear together are called a “side” of a differential. The third spur gear is the output gear, as designated in figure 11-8. This is the only gear pinned to the spider shaft. All the other differential gears, both bevel and spur, are bearing-mounted.

Figure 11-9 is an exploded view of a gear differential showing each of its individual parts. Figure 11-10 is a schematic sketch showing the relationship of the principle parts. For the present we will assume that the two sides of the gear system are the inputs and the gear on the spider shaft is the output. Later we will show that any of these three gears can be either an input or an output.

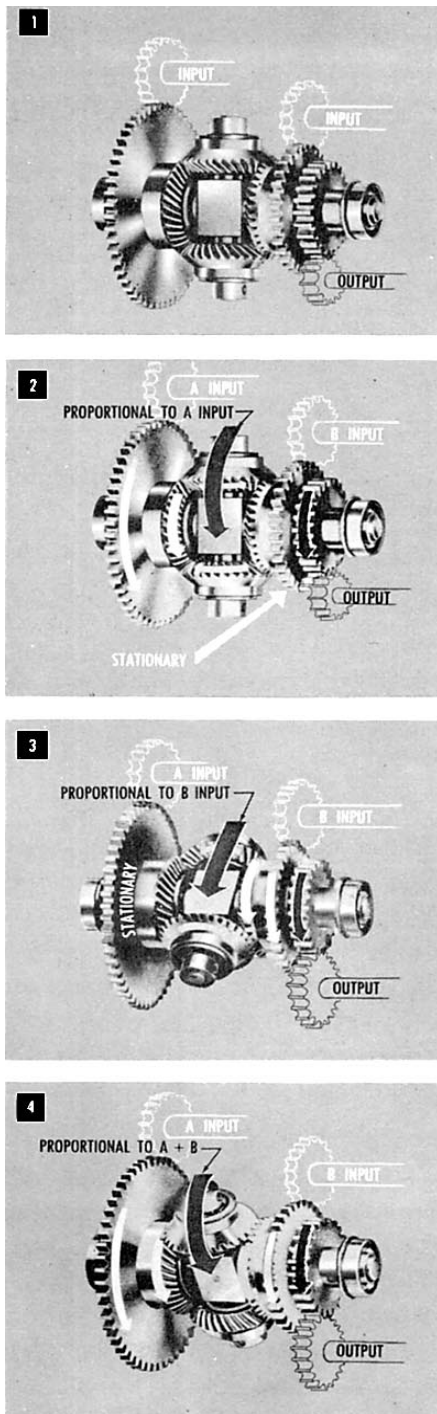

Figure 11-11.—How a differential works.

Now let's look at figure 11-11. In this hookup the two end gears are positioned by the input shafts, which represent the quantities to be added or subtracted. The spider gears do the actual adding and subtracting. They follow the rotation of the two end

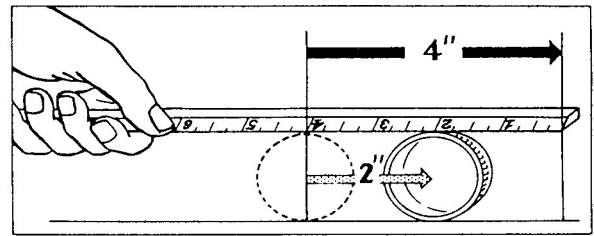

Figure 11-12.—The spider makes only half as many revolutions.

gears, turning the spider shaft several revolutions proportional to the sum, or difference, of the revolutions of the end gears.

Suppose the left side of the differential rotates while the other remains stationary, as in block 2 of figure 11-11. The moving end gear will drive the spider in the same direction as the input and, through the spider shaft and output gear, the output shaft. The output shaft will turn several revolutions proportional to the input.

If the right side is not rotated and the left side is held stationary, as in block 3 of figure 11-11, the same thing will happen. If both input sides of the differential turn in the same direction at the same time, the spider will be turned by both at once, as in block 4 of figure 11-11. The output will be proportional to the two inputs. Actually, the spider makes only half as many revolutions as the revolutions of the end gears, because the spider gears are free to roll between the end gears. To understand this better, let's look at figure 11-12. Here a ruler is rolled across the upper side of a cylindrical drinking glass, pushing the glass along a table top. The glass will roll only half as far as the ruler travels. The spider gears in the differential roll against the end gears in exactly the same way. Of course, you can correct the way the gears work by using a 2:1 gear ratio between the gear on the spider shaft and the gear for the output shaft. Very often, for design purposes, this gear ratio will be found to be different.

When two sides of the differential move in opposite directions, the output of the spider shaft is proportional to the difference of the revolutions of the two inputs. That is because the spider gears are free to turn and the two inputs drive them in opposite directions. If the two inputs are equal and opposite, the spider gears will turn, but the spider shaft will not move. If the two inputs turn in opposite directions for an unequal number of revolutions, the spider gears roll on the end gear that makes the lesser number of revolutions. That rotates the spider in the direction of the input making the greater number of revolution. The motion of the spider shaft

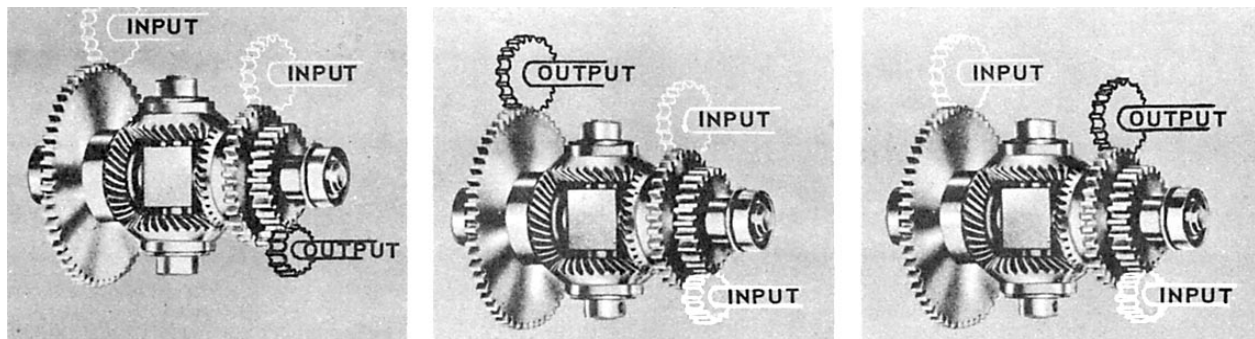

Figure 11-13.—Differential gear hookups.

will be equal to half the difference between the revolutions of the two inputs. A change in the gear ratio to the output shaft can then give us any proportional answer we wish.

We have been describing a hookup wherein the two sides are inputs and the spider shaft is the output. As long as you recognize that the spider follows the end gears for half the sum, or difference, of their revolutions, you don't need to use this type of hookup. You may use the spider shaft as one input and either of the sides as the other. The other side will then become the output. Therefore, you may use three different hookups for any given differential, depending on which is the most convenient mechanically, as shown in figure 11-13.

In chapter 13 of this book, we will describe the use of the differential gear in the automobile. Although this differential is similar in principle, you will see that it is somewhat different in its mechanical makeup.

LINKAGES

A linkage may consist of either one or a combination of the following basic parts:

1. Rod, shaft, or plunger
2. Lever
3. Rocker arm
4. Bell crank

These parts combined will transmit limited rotary or linear motion. To change the direction of a motion, we use cams with the linkage.

Lever-type linkages (fig. 11-14) are used in equipment that you open and close; for instance, valves in electric-hydraulic systems, gates clutches, and clutch-solenoid interlocks. Rocker

arms are merely a variation, or special use, of levers.

Bell cranks primarily transmit motion from a link traveling in one direction to another link moving in a different direction. The bell crank mounts on a fixed

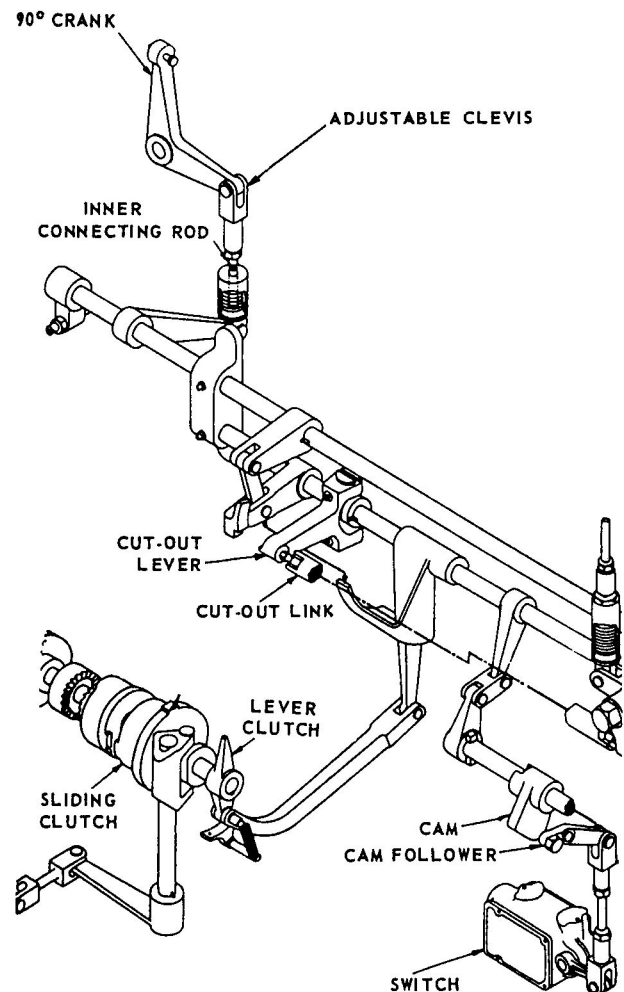

Figure 11-14.—Linkages.

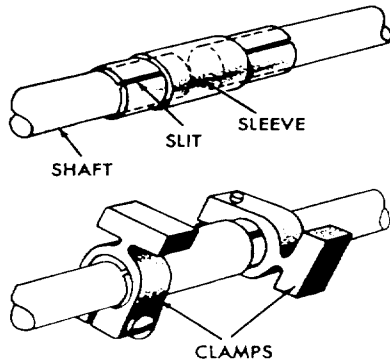

Figure 11-15.-Sleeve coupling.

pivot, and the two links connect at two points in different directions from the pivot. By properly locating the connection points, the output links can move in any desired direction.

All linkages require occasional adjustments or repair, particularly when they become worn. To make the proper adjustments, a person must be familiar with the basic parts that constitute a linkage. Adjustments are normally made by lengthening or shortening the rods and shafts by a clevis or turnbuckle.

COUPLINGS

The term *coupling* applies to any device that holds two parts together. Line shafts that make up several shafts of different lengths may be held together by any of several types of shaft couplings.

SLEEVE COUPLING

You may use the sleeve coupling (fig. 11-15) when shafts are closely aligned. It consists of a metal tube slit at each end. The slitted ends enable the clamps to fasten the sleeve securely to the shaft ends. With the clamps tightened, the shafts are held firmly together and turn as one shaft. The sleeve coupling also serves as a convenient device for making adjustments between units. The weight at the opposite end of the clamp from the screw merely offsets the weight of the screw and clamp arms. Distributing the weight evenly reduces the shaft vibration.

OLDHAM COUPLING

The Oldham coupling, named for its inventor, transmits rotary motion between shafts that are parallel but not always in perfect alignment.

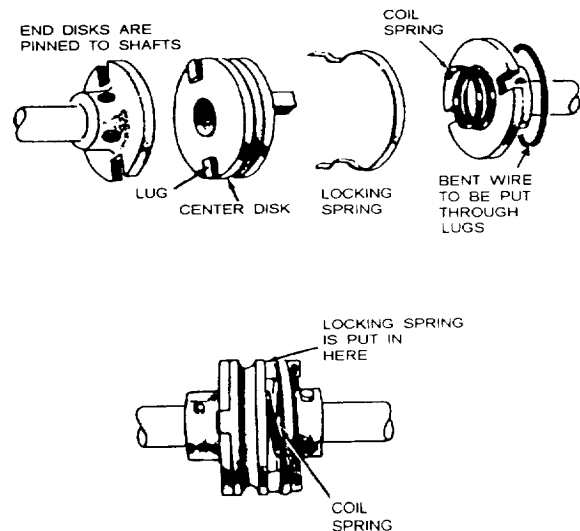

Figure 11-16.-Oldham coupling.

An Oldham coupling (fig. 11-16) consists of a pair of disks, one flat and the other hollow. These disks are pinned to the ends of the shafts. A third (center) disk, with a pair of lugs projecting from each face of the disk, fits into the slots between the two end disks and enables one shaft to drive the other shaft. A coil spring, housed within the center of the hollow end disk, forces the center disk against the flat disk. When the coupling is assembled on the shaft ends, a flat lock spring is slipped into the space around the coil spring. The ends of the flat spring are formed so that when they are pushed into the proper place, the ends of the spring push out and lock around the lugs. A lock wire is passed between the holes drilled through the projecting lugs to guard the assembly. The coil spring compensates for any change in shaft length. (Changes in temperature may cause the shaft length to vary.)

The disks, or rings, connecting the shafts allow a small amount of radial play. This play allows a small amount of misalignment of the shafts as they rotate. You can easily connect and disconnect the Oldham type couplings to realign the shafts.

OTHER TYPES OF COUPLINGS

We use four other types of couplings extensively in naval equipment:

1. The fixed (sliding lug) coupling, which is nonadjustable; it does allow for a small amount of misalignment in shafting (fig. 11-17).
2. The flexible coupling (fig. 11-18), which connects two shafts by a metal disk. Two coupling hubs,

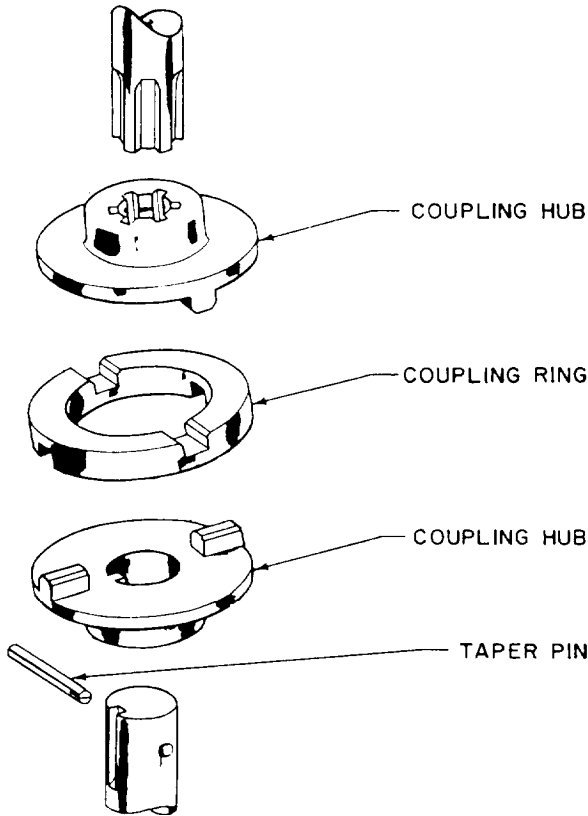

Figure 11-17.-Fixed coupling.

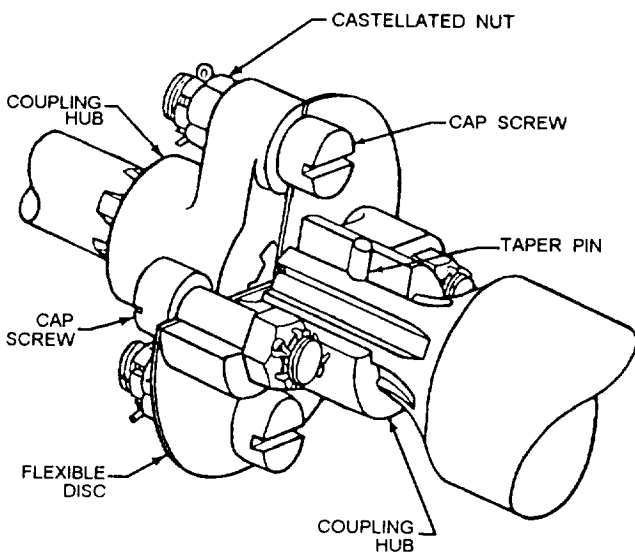

Figure 11-18.-Flexible coupling.

each splined to its respective shaft, are bolted to the metal disk. The flexible coupling provides a small amount of flexibility to allow for a slight axial misalignment of the shafts.

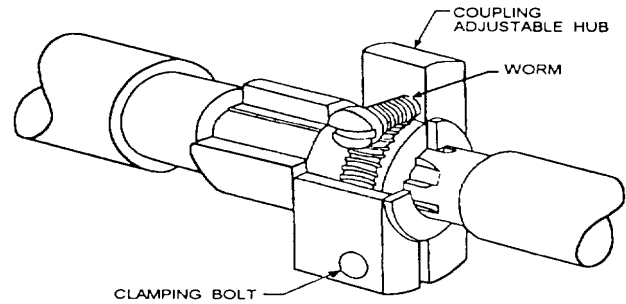

Figure 11-19.-Adjustable (vernier) coupling.

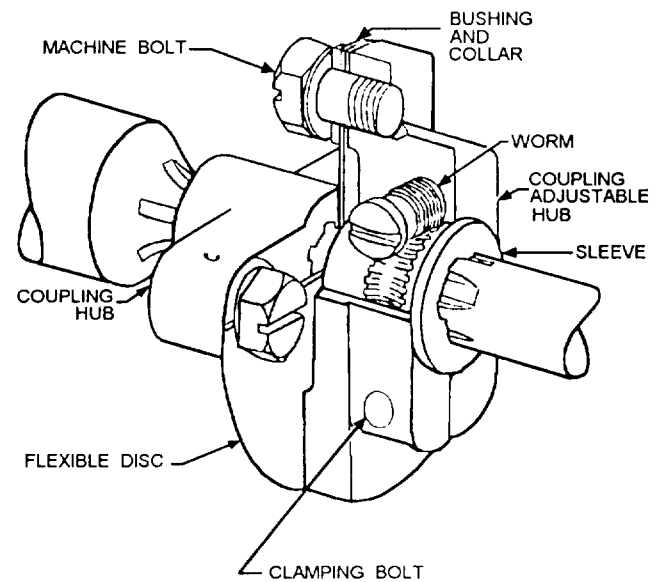

Figure 11-20.-Adjustable flexible (vernier) coupling.

3. The adjustable (vernier) coupling, which provides a means of finely adjusting the relationship of two interconnected rotating shafts (fig. 11-19). Loosening a clamping bolt and turning an adjusting worm allows one shaft to rotate while the other remains stationary. After attaining the proper relationship, you retighten the clamping bolt to lock the shafts together again.

4. The adjustable flexible (vernier) coupling (fig. 11-20), which is a combination of the flexible disk coupling and the adjustable (vernier) coupling.

UNIVERSAL JOINT

To couple two shafts in different planes, you need to use a universal joint. Universal joints have various

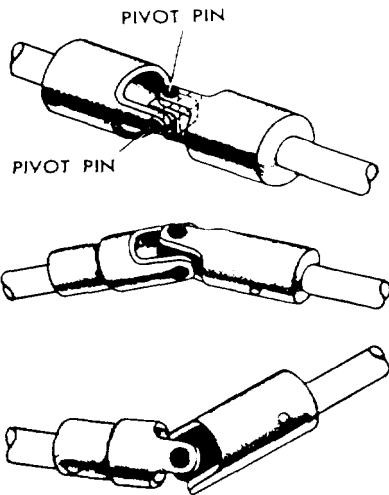

Figure 11-21.-Universal joint (Hooke type).

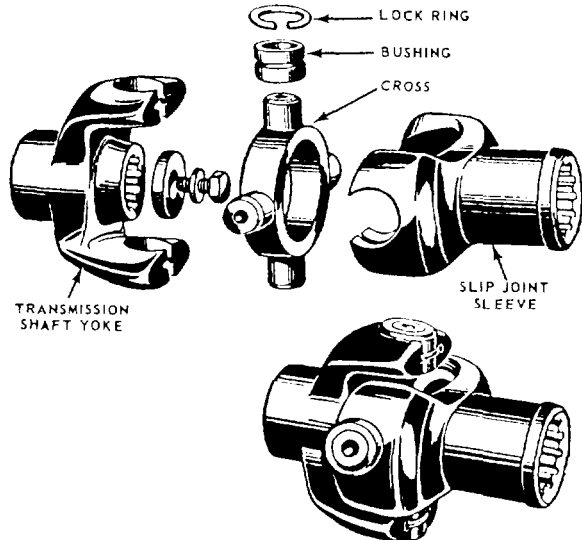

Figure 11-22.-Ring-and-trunnion universal joint.

forms. They are used in nearly all types and classes of machinery. An elementary universal joint, sometimes called a Hooke joint (fig. 11-21), consists of two U-shaped yokes fastened to the ends of the shafts to be connected. Within these yokes is a cross-shaped part that holds the yokes together and allows each yoke to bend, or pivot, in relation to the other. With this arrangement, one shaft can drive the other even though the angle between the two is as great as 25° from alignment.

Figure 11-22 shows a ring-and-trunnion universal joint. It is merely a slight modification of the old Hooke joint. Automobile drive shaft systems use two, and

sometimes three, of these joints. You will read more about these in chapter 13 of this book.

The Bendix-Weiss universal joint (fig. 11-23) provides smoother torque transmission but less structural strength. In this type of joint, four large balls transmit the rotary force, with a smaller ball as a spacer. With the Hooke type universal joint, a whipping motion occurs as the shafts rotate. The amount of whip depends on the degree of shaft misalignment. The Bendix-Weiss joint does not have this disadvantage; it transmits rotary motion with a constant angular velocity. However, this type of joint is both more expensive to manufacture and of less strength than the Hooke type.

CAMS

A cam is a rotating or sliding piece of machinery (as a wheel or a projection on a wheel). A cam transfers motion to a roller moving against its edge or to a pin free to move in a groove on its face. A cam may also receive motion from such a roller or pin. Some cams do not move at all, but cause a change of motion in the contacting part. Cams are not ordinarily used to transmit power in the sense that gear trains are used. They are used to modify mechanical movement, the power for which is furnished through other means. They may control other mechanical units, or they may synchronize or lock together two or more engaging units.

Cams are of many shapes and sizes and are widely used in machines and machine tools (fig. 11-24). We classify cams as

1. radial or plate cams,
2. cylindrical or barrel cams, and
3. pivoted beams.

A similar type of cam includes drum or barrel cams, edge cams, and face cams.

The drum or barrel cam has a path cut around its outside edge in which the roller or follower fits. It imparts a to-and-from motion to a slide or lever in a plane parallel to the axis of the cam. Sometimes we build these cams upon a plain drum with cam plates attached.

Plate cams are used in $5''/38$ and $3''/50$ guns to open the breechblock during counter-recoil.

Edge or peripheral cams, also called disc cams, operate a mechanism in one direction only. They rely on gravity or a spring to hold the roller in contact with the edge of the cam. The shape of the cam suits the action required.

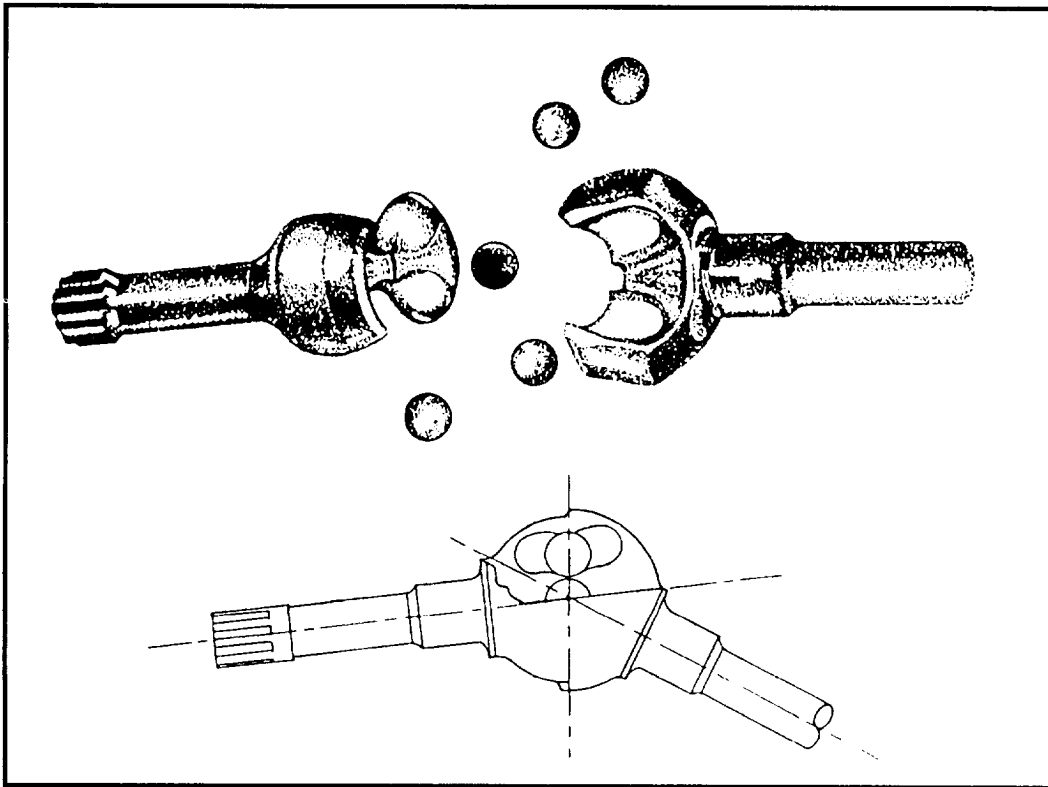

Figure 11-23.-Bendix-Weiss universal joint.

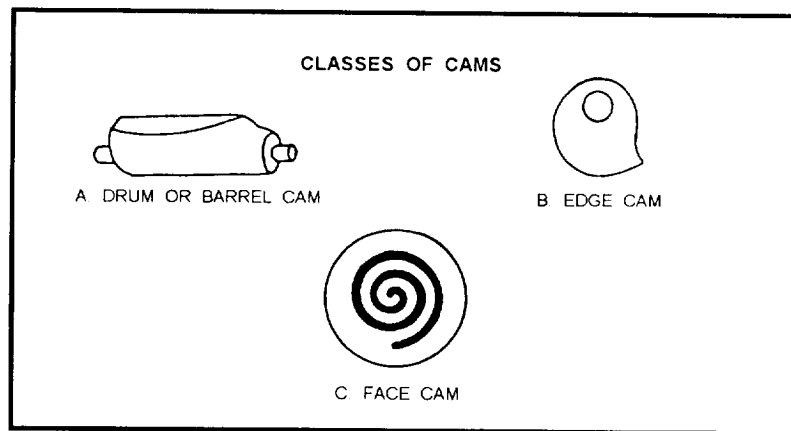

Figure 11-24.-Classes of cams.

Face cams have a groove or slot cut in the face to provide a path for the roller. They operate a lever or other mechanism positively in both directions. The roller is guided by the sides of the slot. Such a groove can be seen on top of the bolt of the Browning .30-caliber machine gun or in fire control cams. The shape of the

groove determines the name of the cam, for example, the square cam.

CLUTCHES

A clutch is a form of a coupling. It is designed to connect or disconnect a driving and a driven part as a

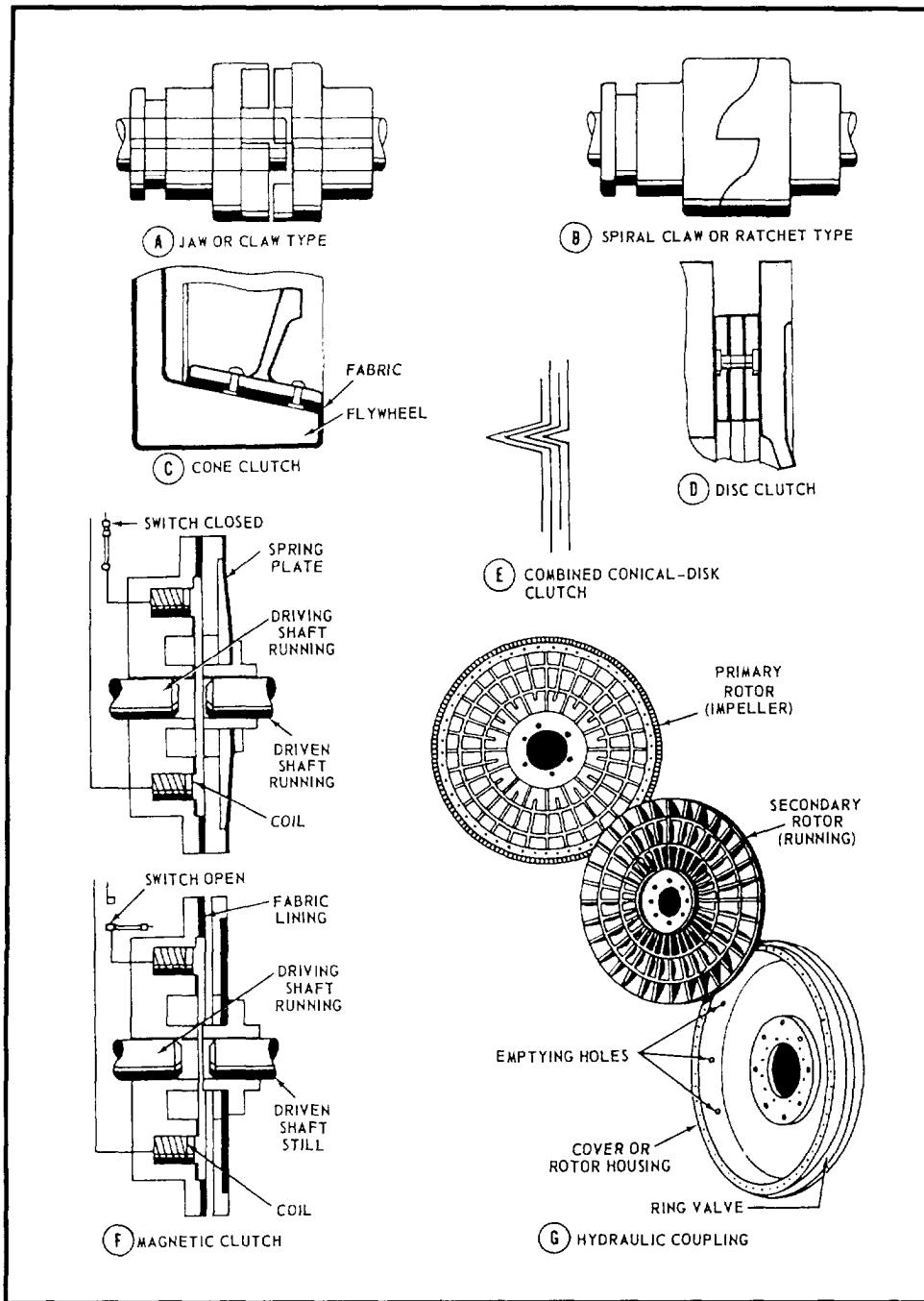

Figure 11-25. Types of clutches.

means of stopping or starting the driven part. There are two general classes of clutches: positive clutches and friction clutches.

Positive clutches have teeth that interlock. The simplest is the jaw or claw type (fig. 11-25, A), usable only at low speeds. The teeth of the spiral claw or ratchet type (fig. 11-25, B) interlock only one way—they cannot be reversed. An example of this type of clutch is

that seen in bicycles. It engages the rear sprocket with the rear wheel when the pedals are pushed forward and lets the rear wheel revolve freely when the pedals are stopped.

The object of a friction clutch is to connect a rotating member to one that is stationary, to bring it up to speed, and to transmit power with a minimum of slippage. Figure 11-25, C, shows a cone clutch commonly used

in motor trucks. Friction clutches may be single-cone or double-cone. Figure 11-25, D, shows a disc clutch, also used in autos. A disc clutch also may have several plates (multiple-disc clutch). In a series of discs, each driven disc is located between two driving discs. You may have had experience with a multiple-disc clutch on your car.

The Hele-Shaw clutch is a combined conical-disc clutch (fig. 11-25, E). Its groove permits cooling and circulation of oil. Single-disc clutches are frequently dry clutches (no lubrication); multiple-disc clutches may be dry or wet (either lubricated or operated with oil).

Magnetic clutches are a recent development in which the friction surfaces are brought together by magnetic force when the electricity is turned on (fig. 11-25, F). The induction clutch transmits power without contact between the driving and driven parts.

The way pressure is applied to the rim block, split ring, band, or roller determines the names of expanding clutches or rim clutches. In one type of expanding clutch, right- and left-hand screws expand as a sliding sleeve moves along a shaft and expands the band against the rim. The centrifugal clutch is a special application of a block clutch.

Machines containing heavy parts to be moved, such as a rolling mill, use oil clutches. The grip of the coil

causes great friction when it is thrust onto a cone on the driving shaft. Yet the clutch is very sensitive to control.

Diesel engines and transportation equipment use pneumatic and hydraulic clutches. Hydraulic couplings (fig. 11-25, G), which also serve as clutches, are used in the hydraulic A-end of electric-hydraulic gun drives.

SUMMARY

In this chapter we discussed the following elements and mechanisms used in naval machinery:

Two types of bearings are used in naval machinery: sliding and antifrictional.

Springs are another element used in machinery.

Springs can be twisted, pulled, or stretched by force and can return to their original shape when the force is released.

One basic mechanism of machines is the gear

differential. A gear differential is a mechanism that is capable of adding and subtracting mechanically. Other basic mechanisms include linkages, couplings, cams and cam followers, and clutches.